



NEHRU COLLEGE OF ENGINEERING AND RESEARCH CENTRE
(NAAC Accredited)
 (Approved by AICTE, Affiliated to APJ Abdul Kalam Technological University,
 Kerala)



DEPARTMENT OF MECHANICAL ENGINEERING

COURSE MATERIALS



MET 205-METALLURGY & MATERIAL SCIENCE

VISION OF THE INSTITUTION

To mould true citizens who are millennium leaders and catalysts of change through excellence in education.

MISSION OF THE INSTITUTION

NCERC is committed to transform itself into a center of excellence in Learning and Research in Engineering and Frontier Technology and to impart quality education to mould technically competent citizens with moral integrity, social commitment and ethical values.

We intend to facilitate our students to assimilate the latest technological know-how and to imbibe discipline, culture and spiritually, and to mould them in to technological giants, dedicated research scientists and intellectual leaders of the country who can spread the beams of light and happiness among the poor and the underprivileged.

ABOUT DEPARTMENT

- ◆ Established in: 2002
- ◆ Course offered : B.Tech in Mechanical Engineering
- ◆ Approved by AICTE New Delhi and Accredited by NAAC

- ◆ Affiliated to the University of Dr. A P J Abdul Kalam Technological University.

DEPARTMENT VISION

Producing internationally competitive Mechanical Engineers with social responsibility & sustainable employability through viable strategies as well as competent exposure oriented quality education.

DEPARTMENT MISSION

1. Imparting high impact education by providing conducive teaching learning environment.
2. Fostering effective modes of continuous learning process with moral & ethical values.
3. Enhancing leadership qualities with social commitment, professional attitude, unity, team spirit & communication skill.
4. Introducing the present scenario in research & development through collaborative efforts blended with industry & institution.

PROGRAMME EDUCATIONAL OBJECTIVES

- PEO1:** Graduates shall have strong practical & technical exposures in the field of Mechanical Engineering & will contribute to the society through innovation & enterprise.
- PEO2:** Graduates will have the demonstrated ability to analyze, formulate & solve design engineering / thermal engineering / materials & manufacturing / design issues & real life problems.
- PEO3:** Graduates will be capable of pursuing Mechanical Engineering profession with good communication skills, leadership qualities, team spirit & communication skills.
- PEO4:** Graduates will sustain an appetite for continuous learning by pursuing higher education & research in the allied areas of technology.

PROGRAM OUTCOMES (POS)

Engineering Graduates will be able to:

1. **Engineering knowledge:** Apply the knowledge of mathematics, science, engineering fundamentals, and an engineering specialization to the solution of complex engineering problems.
2. **Problem analysis:** Identify, formulate, review research literature, and analyze complex engineering problems reaching substantiated conclusions using first principles of mathematics, natural sciences, and engineering sciences.
3. **Design/development of solutions:** Design solutions for complex engineering problems and design system components or processes that meet the specified needs with appropriate consideration for the public health and safety, and the cultural, societal, and environmental considerations.
4. **Conduct investigations of complex problems:** Use research-based knowledge and research methods including design of experiments, analysis and interpretation of data, and synthesis of the information to provide valid conclusions.
5. **Modern tool usage:** Create, select, and apply appropriate techniques, resources, and modern engineering and IT tools including prediction and modeling to complex engineering

activities with an understanding of the limitations.

6. **The engineer and society:** Apply reasoning informed by the contextual knowledge to assess societal, health, safety, legal and cultural issues and the consequent responsibilities relevant to the professional engineering practice.
7. **Environment and sustainability:** Understand the impact of the professional engineering solutions in societal and environmental contexts, and demonstrate the knowledge of, and need for sustainable development.
8. **Ethics:** Apply ethical principles and commit to professional ethics and responsibilities and norms of the engineering practice.
9. **Individual and teamwork:** Function effectively as an individual, and as a member or leader in diverse teams, and in multidisciplinary settings.
10. **Communication:** Communicate effectively on complex engineering activities with the engineering community and with society at large, such as, being able to comprehend and write effective reports and design documentation, make effective presentations, and give and receive clear instructions.
11. **Project management and finance:** Demonstrate knowledge and understanding of the engineering and management principles and apply these to one's own work, as a member and leader in a team, to manage projects and in multidisciplinary environments.
12. **Life-long learning:** Recognize the need for, and have the preparation and ability to engage in independent and life-long learning in the broadest context of technological change.

PROGRAM SPECIFIC OUTCOMES (PSO)

PSO1: Students will be able to apply principles of engineering, basic sciences & analytics including multi variant calculus & higher order partial differential equations..

PSO2: Students will be able to perform modeling, analyzing, designing & simulating physical systems, components & processes.

PSO3: Students will be able to work professionally on mechanical systems, thermal systems & production systems.

COURSE OUTCOMES

CO1	Understand the basic chemical bonds, crystal structures (BCC, FCC, and HCP), and their relationship with the properties.
CO2	Classify various supports and loadings and apply the equations of equilibrium for forces system in space Analyze the microstructure of metallic materials using phase diagrams and modify the microstructure and properties using different heat treatments.
CO3	How to quantify mechanical integrity and failure in materials.
CO4	Apply the basic principles of ferrous and non-ferrous metallurgy for selecting materials for specific applications.
CO5	Define and differentiate engineering materials on the basis of structure and properties for engineering applications Apply the fundamental law of mechanics and equilibrium equations for planar problems.

MAPPING OF COURSE OUTCOMES WITH PROGRAM OUTCOMES

	PO1	PO2	PO3	PO4	PO5	PO6	PO7	PO8	PO9	PO10	PO11	PO12	PSO1	PSO2	PSO3
CO1	3	-	-	-	-	-	-	-	-	-	-	-	-	-	-
CO2	-	3	-	-	-	-	-	-	-	-	-	-	-	-	-
CO3	-	-	-	2	-	-	-	-	-	-	-	-	-	-	-
CO4	-	-	-	-	3	-	2	-	-	-	-	-	-	-	-
CO5	-	-	-	-	-	-	-	-	-	-	-	-	-	-	2

Note: H-Highly correlated=3, M-Medium correlated=2, L-Less correlated=1

SYLLABUS

SYLLABUS

2014

MODULE - I

Earlier and present development of atomic structure - Primary bonds: - characteristics of covalent, ionic and metallic bond - properties based on atomic bonding: - Secondary bonds: - classification, application. (*Brief review only*).

Crystallography: - SC, BCC, FCC, HCP structures, APF - theoretical density simple problems - Miller Indices: - crystal plane and direction - Modes of plastic deformation: - Slip and twinning -Schmid's law - Crystallization: Effects of grain size, Hall - Petch theory, simple problems.

MODULE - II

Classification of crystal imperfections - forest of dislocation, role of surface defects on crack initiation- Burgers vector -Frank Read source - Correlation of dislocation density with strength and nano concept - high and low angle grain boundaries- driving force for grain growth and applications - Polishing and etching - X - ray diffraction, simple problems -SEM and TEM - Diffusion in solids, Fick's laws, mechanisms, applications of diffusion in mechanical engineering, simple problems.

MODULE - III

Phase diagrams: - need of alloying - classification of alloys - Hume Rothery's rule - equilibrium diagram of common types of binary systems: five types - Coring - lever rule and Gibb's phase rule - Reactions- Detailed discussion on Iron-Carbon equilibrium diagram with microstructure and properties -Heat treatment: - TTT, CCT diagram, applications - Tempering- Hardenability, Jominy end quench test, applications- Surface hardening methods.

MODULE - IV

Strengthening mechanisms - cold and hot working - alloy steels: how alloying elements affecting properties of steel - nickel steels - chromium steels - high speed steels -cast irons - principal non ferrous alloys.

MODULE - V

Fatigue: - creep -DBTT - super plasticity - need, properties and applications of composites, super alloy, intermetallics, maraging steel, Titanium - Ceramics:- structures, applications.

QUESTION BANK

MODULE I			
Q:N O:	QUESTIONS	CO	K L
1	Narrate Schmid's law	CO1	K2
2	Explain the term critical resolved shear stress?	CO1	K3
3	Plastic deformation by slip explanation with neat diagram	CO1	K2
4	Plastic deformation by twinning explanation with neat diagram	CO1	K2
5	Discuss crystallographic directions and show the crystallographic direction (111)	CO1	K2
6	Define unit cell and coordination number	CO1	K2
7	Explain (i) Elastic (ii) Anelastic (c) Visco elastic materials	CO1	K2
8	Discuss the methodology to determine crystallographic planes and directions using miller indices	CO1	K3
9	Explain APF? Calculate it for SCC, BCC, FCC, HCP crystal structures?	CO1	K2
10	Distinguish between Slip and Twining?	CO1	K2
11	Define the terms space lattice and unit cell with help of neat sketches?	CO1	K2
12	Discuss polymorphism and allotropy? Give some of its examples.	CO1	K2
13	Explain BCC, FCC and HCP crystal structures.	CO1	K2
MODULE II			
1	Give a detailed account of the types of the surface imperfections	CO2	K2
2	Differentiate edge and screw dislocation	CO2	K4
3	Analyse the mechanism of solidification of crystalline materials	CO2	K2
4	Sketch and explain Burger's circuit for screw dislocation	CO2	K5
5	Explain Fick's law of diffusion	CO2	K5
6	Write a short note on imperfections in crystals and its influence on mechanical properties.	CO2	K3
7	Discuss different types of defects in crystal structure	CO2	K5
8	Write a short notes on point defect	CO2	K2
9	Write a short notes on Burger's vector.	CO2	K5
10	Describe Hall-Petch equation.	CO2	K5
11	Describe the frank-read source for dislocation generation	CO2	K3
12	Define recrystallization?	CO2	K5
13	Narrate Fick's law of diffusion	CO2	K5

MODULE III

1	Explain the Hume-Rothery rules	CO3	K3
2	Draw the Fe-FeC equilibrium phase diagram, indicate the various phases and write the invariant reactions.	CO3	K3
3	Explain the following terms: (a)Component (b)Degrees of freedom(c) Eutectic system	CO3	K2
4	Give Gibbs phase rule	CO3	K3
5	Analyse the alloying capacity of iron and carbon using a suitable thermodynamic diagram. Indicate all the relevant phases and invariant reactions. Also explain the term pearlite.	CO3	K5
6	Explain the lead Tin phase diagram in detail.	CO3	K3
7	Draw the phase diagram for pure water	CO3	K2
8	Draw any eutectic phase diagram. Explain in detail mentioning the various phases and microstructures for eutectic hypoeutectic and hypereutectic mixtures.	CO3	K5
9	Draw the iron carbon equilibrium diagram naming all the phases and invariant reactions. Also explain the term pearlite.	CO3	K5
10	With the help of a plot explain the phases of an Fe-FeC plot.	CO3	K2

MODULE IV

1	Explain case hardening methods. (7 marks)	CO4	K2
2	Explain cold and hot working (3 marks)	CO4	K1
3	What are cast irons? Explain its classification	CO4	K2
4	Explain the terms recovery, recrystallization and grain growth in detail	CO4	K3
5	What are strengthening mechanisms? Explain. (5 marks)	CO4	K1
6	Explain Jominy end quench test.(5 marks)	CO4	K2
7	What are alloy steels? Explain the effect of adding alloying elements.(6 marks)	CO4	K3
8	List out 4 major alloying elements used in steels and their specific purposes/ advantages.	CO4	K2
9	How are heat treatment processes classified. Explain the various isothermal heat treatments employed during hardening process.	CO4	K1
10	Explain surface treatment. In detail explain selective hardening processes.	CO4	K2
11	Explain the effects, functions etc of the following as alloying elements(i) Manganese(ii) Chromium (iii) Phosphorus	CO4	K3
12	What are high speed steels. Explain	CO4	K1
13	Enumerate about copper and its alloys	CO4	K2

MODULE V

1	Explain the mechanism of fatigue	CO5	K2
2	Explain the mechanism of creep	CO5	K4

3	What are the types of ceramics	CO5	K4 4
4	What is shape memory alloy	CO5	K2
5	Explain the structure of composites	CO5	K3
6	Explain the term superplasticity	CO5	K2
7	Explain the tests for creep	CO5	K2
8	Explain endurance limit and SN curves	CO5	K3
9	Narrate the importance of smart materials		
10	Discuss the various tests for fatigue		

APPENDIX 1

CONTENT BEYOND THE SYLLABUS

S:NO.	WEB SOURCE REFERENCES
1	https://nptel.ac.in/courses/113/106/113106032/
2	https://nptel.ac.in/content/storage2/courses/113106032/downloads/3-Quiz.pdf
3	http://www.istl.org/02-spring/internet.html

MODULE – I

Introduction

Materials science, also commonly known as materials science and engineering, is an interdisciplinary field which deals with the discovery and design of new materials. This relatively new scientific field involves studying materials through the materials paradigm (synthesis, structure, properties and performance). It incorporates elements of physics and chemistry, and is at the forefront of nano science and nanotechnology research. In recent years, materials science has become more widely known as a specific field of science and engineering.

Importance of Materials

A material is defined as a substance (most often a solid, but other condensed phases can be included) that is intended to be used for certain applications. There are a myriad of materials around us—they can be found in anything from buildings to spacecrafts. Materials can generally be divided into two classes: crystalline and non-crystalline. The traditional examples of materials are metals, ceramics and polymers. New and advanced materials that are being developed include semiconductors, nanomaterials, biomaterials etc.

The material of choice of a given era is often a defining point. Phrases such as Stone Age, Bronze Age, Iron Age, and Steel Age are great examples. Originally deriving from the manufacture of ceramics and its putative derivative metallurgy, materials science is one of the oldest forms of engineering and applied science. Modern materials science evolved directly from metallurgy, which itself evolved from mining and (likely) ceramics and the use of fire. A major breakthrough in the understanding of materials occurred in the late 19th century, when the American scientist Josiah Willard Gibbs demonstrated that the thermodynamic properties related to atomic structure in various phases are related to the physical properties of a material. Important elements of modern materials science are a product of the space race: the understanding and engineering of the metallic alloys, and silica and carbon materials, used in the construction of space vehicles enabling the exploration of space. Materials science has driven, and been driven by, the development of revolutionary technologies such as plastics, semiconductors, and biomaterials.

Before the 1960s (and in some cases decades after), many materials science departments were named metallurgy departments, reflecting the 19th and early 20th century emphasis on metals. The field has since broadened to include every class of materials, including ceramics, polymers, semiconductors, magnetic materials, medical implant materials, biological materials and nanomaterials (materiomics).

Historical Perspective

Materials are so important in the development of civilization that we associate ages with them. In the origin of human life on earth, the Stone Age, people used only natural materials like stone, clay, skins, and wood. When people found copper and how to make it harder by alloying, the Bronze Age started about 3000 BC. The use of iron and steel, stronger materials that gave advantage in wars started at about 1200 BC. The next big step was the discovery of a cheap process to make steel around 1850, which enabled the railroads and the building of the modern infrastructure of the industrial world.

Why Study Materials Science and Engineering?

- To be able to select a material for a given use based on considerations of cost and performance.
- To understand the limits of materials and the change of their properties with use.
- To be able to create a new material that will have some desirable properties.

All engineering disciplines need to know about materials. Even the most immaterial like software or system engineering depend on the development of new materials, which in turn alter the economics, like software-hardware trade-offs. Increasing applications of system engineering are in materials manufacturing (industrial engineering) and complex environmental systems.

Classification of Materials

Like many other things, materials are classified in groups, so that our brain can handle the complexity. One could classify them according to structure, or properties, or use. The one that we will use is according to the way the atoms are bound together:

Metals: The valence electrons are detached from atoms, and spread in an 'electron sea' that "glues" the ions together. Metals are usually strong, conduct electricity and heat well and are opaque to light (shiny if polished). Examples: aluminum, steel, brass, gold.

Semiconductors: The bonding is covalent (electrons are shared between atoms). Their electrical properties depend extremely strongly on minute proportions of contaminants. They are opaque to visible light but transparent to the infrared. Examples: Si, Ge, GaAs.

Ceramics: Atoms behave mostly like either positive or negative ions, and are bound by Coulomb forces between them. They are usually combinations of metals or semiconductors with oxygen, nitrogen or carbon (oxides, nitrides, and carbides). Examples: glass, porcelain, many minerals.

Polymers: are bound by covalent forces and also by weak van der Waals forces, and usually based on H, C and other non-metallic elements. They decompose at moderate temperatures (100 – 400 C), and are lightweight. Other properties vary greatly. Examples: plastics (nylon, teflon, polyester) and rubber. Other categories are not based on bonding. A particular microstructure identifies

Composites: Composites made of different materials in intimate contact (example: fiberglass, concrete, wood) to achieve specific properties. **Biomaterials** can be any type of material that is biocompatible and used, for instance, to replace human body parts.

Advanced Materials

Materials used in "High-Tec" applications, usually designed for maximum performance, and normally expensive. Examples are titanium alloys for supersonic airplanes, magnetic alloys for computer disks, special ceramics for the heat shield of the space shuttle, etc.

Modern Material's Needs

- Engine efficiency increases at high temperatures: requires high temperature withstanding materials

- Use of nuclear energy requires solving problem with residues, or advances in nuclear waste processing.
- Hypersonic flight requires materials that are light, strong and resist high temperatures.
- Optical communications require optical fibers that absorb light negligibly.
- Civil construction – materials for unbreakable windows.
- Structures: materials that are strong like metals and resist corrosion like plastics.

Atomic models

Thomson atomic model

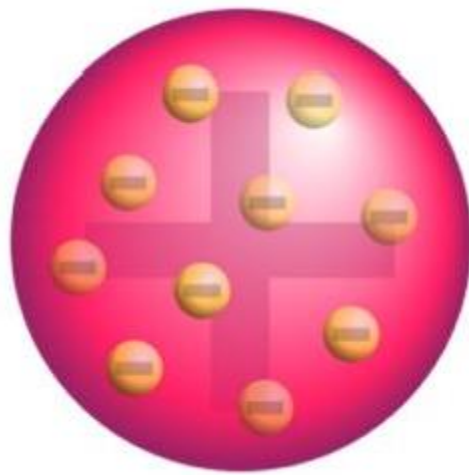

A schematic presentation of the plum pudding model of the atom; in Thomson's mathematical model the "corpuscles" (or modern electrons) were arranged non-randomly, in rotating rings

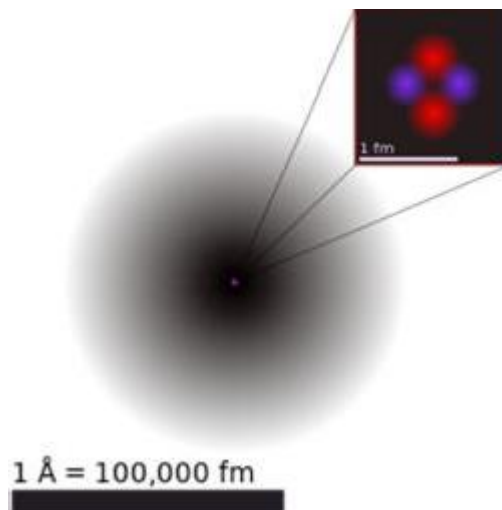

The current model of the sub-atomic structure involves a dense nucleus surrounded by a probabilistic "cloud" of electrons

The **plum pudding model** was a model of the atom that incorporated the recently discovered electron, and was proposed by J. J. Thomson in 1904. Thomson had discovered the electron in 1897. The plum pudding model was abandoned after discovery of the atomic nucleus. The plum pudding model of the atom is also known as the "Blueberry Muffin" model.

In this model, the atom is composed of electrons (which Thomson still called "corpuscles", though G. J. Stoney had proposed that atoms of electricity be called electrons in 1894) surrounded by a soup of positive charge to balance the electrons' negative charges, like negatively charged "raisins" surrounded by positively charged "pudding". The electrons (as we know them today) were thought to be positioned throughout the atom, but with many structures possible for positioning multiple electrons, particularly rotating rings of electrons (see below). Instead of a soup, the atom was also sometimes said to have had a "cloud" of positive charge.

With this model, Thomson abandoned his earlier "nebular atom" hypothesis in which the atom was composed of immaterial vortices. Now, at least part of the atom was to be composed of Thomson's particulate negative "corpuscles", although the rest of the positively charged part of the atom remained somewhat nebulous and ill-defined.

The 1904 Thomson model was disproved by the 1909 gold foil experiment of Hans Geiger and Ernest Marsden. This was interpreted by Ernest Rutherford in 1911 to imply a very small nucleus of the atom containing a very high positive charge (in the case of gold, enough to balance about 100 electrons), thus leading to the Rutherford model of the atom. Although gold has an atomic number of 79, immediately after Rutherford's paper appeared in 1911 Antonius Van den Broek made the intuitive suggestion that atomic number is nuclear charge. The matter required experiment to decide. Henry Moseley's work showed experimentally in 1913 (see Moseley's law) that the effective nuclear charge was very close to the atomic number (Moseley found only one unit difference), and Moseley referenced only the papers of Van den Broek and Rutherford. This work culminated in the solar-system-like (but quantum-limited) Bohr model of the atom in the

same year, in which a nucleus containing an atomic number of positive charge is surrounded by an equal number of electrons in orbital shells. Bohr had also inspired Moseley's work.

Thomson's model was compared (though not by Thomson) to a British dessert called plum pudding, hence the name. Thomson's paper was published in the March 1904 edition of the *Philosophical Magazine*, the leading British science journal of the day. In Thomson's view: the atoms of the elements consist of a number of negatively electrified corpuscles enclosed in a sphere of uniform positive electrification.

In this model, the electrons were free to rotate within the blob or cloud of positive substance. These orbits were stabilized in the model by the fact that when an electron moved farther from the center of the positive cloud, it felt a larger net positive inward force, because there was more material of opposite charge, inside its orbit (see Gauss's law). In Thomson's model, electrons were free to rotate in rings which were further stabilized by interactions between the electrons, and spectra were to be accounted for by energy differences of different ring orbits. Thomson attempted to make his model account for some of the major spectral lines known for some elements, but was not notably successful at this. Still, Thomson's model (along with a similar Saturnian ring model for atomic electrons, also put forward in 1904 by Nagaoka after James Clerk Maxwell's model of Saturn's rings), were earlier harbingers of the later and more successful solar-system-like Bohr model of the atom.

Rutherford model

Rutherford overturned Thomson's model in 1911 with his well-known gold foil experiment in which he demonstrated that the atom has a tiny, heavy nucleus. Rutherford designed an experiment to use the alpha particles emitted by a radioactive element as probes to the unseen world of atomic structure.

Rutherford presented his own physical model for subatomic structure, as an interpretation for the unexpected experimental results. In it, the atom is made up of a central charge (this is the modern atomic nucleus, though Rutherford did not use the term "nucleus" in his paper) surrounded by a

cloud of (presumably) orbiting electrons. In this May 1911 paper, Rutherford only commits himself to a small central region of very high positive or negative charge in the atom.

For concreteness, consider the passage of a high speed α particle through an atom having a positive central charge $N e$, and surrounded by a compensating charge of N electrons.

From purely energetic considerations of how far particles of known speed would be able to penetrate toward a central charge of $100 e$, Rutherford was able to calculate that the radius of his gold central charge would need to be less (how much less could not be told) than 3.4×10^{-14} metres. This was in a gold atom known to be 10^{-10} meters or so in radius—a very surprising finding, as it implied a strong central charge less than $1/3000^{\text{th}}$ of the diameter of the atom.

The Rutherford model served to concentrate a great deal of the atom's charge and mass to a very small core, but didn't attribute any structure to the remaining electrons and remaining atomic mass. It did mention the atomic model of Hantaro Nagaoka, in which the electrons are arranged in one or more rings, with the specific metaphorical structure of the stable rings of Saturn. The plum pudding model of J.J. Thomson also had rings of orbiting electrons. Jean Baptiste Perrin claimed in his Nobel Lecture that he was the first one to suggest the model in his paper dated 1901.

The Rutherford paper suggested that the central charge of an atom might be "proportional" to its atomic mass in hydrogen mass units u (roughly $1/2$ of it, in Rutherford's model). For gold, this mass number is 197 (not then known to great accuracy) and was therefore modeled by Rutherford to be possibly 196 u . However, Rutherford did not attempt to make the direct connection of central charge to atomic number, since gold's "atomic number" (at that time merely its place number in the periodic table) was 79, and Rutherford had modeled the charge to be about $+ 100$ units (he had actually suggested 98 units of positive charge, to make half of 196). Thus, Rutherford did not formally suggest the two numbers (periodic table place, 79, and nuclear charge, 98 or 100) might be exactly the same.

Bohr model

In the early 20th century, experiments by Ernest Rutherford established that atoms consisted of a diffuse cloud of negatively charged electrons surrounding a small, dense, positively charged nucleus. Given this experimental data, Rutherford naturally considered a planetary-model atom, the Rutherford model of 1911 – electrons orbiting a solar nucleus – however, said planetary-model atom has a technical difficulty. The laws of classical mechanics (i.e. the Larmor formula), predict that the electron will release electromagnetic radiation while orbiting a nucleus. Because the electron would lose energy, it would rapidly spiral inwards, collapsing into the nucleus on a timescale of around 16 picoseconds. This atom model is disastrous, because it predicts that all atoms are unstable.

Also, as the electron spirals inward, the emission would rapidly increase in frequency as the orbit got smaller and faster. This would produce a continuous smear, in frequency, of electromagnetic radiation. However, late 19th century experiments with electric discharges have shown that atoms will only emit light (that is, electromagnetic radiation) at certain discrete frequencies.

To overcome this difficulty, Niels Bohr proposed, in 1913, what is now called the Bohr model of the atom. He suggested that electrons could only have certain classical motions:

1. Electrons in atoms orbit the nucleus.
2. The electrons can only orbit stably, without radiating, in certain orbits (called by Bohr the "stationary orbits") at a certain discrete set of distances from the nucleus. These orbits are associated with definite energies and are also called energy shells or energy levels. In these orbits, the electron's acceleration does not result in radiation and energy loss as required by classical electromagnetics.
3. Electrons can only gain and lose energy by jumping from one allowed orbit to another, absorbing or emitting electromagnetic radiation with a frequency ν determined by the energy difference of the levels according to the Planck relation:

where h is Planck's constant. The frequency of the radiation emitted at an orbit of period T is as it would be in classical mechanics; it is the reciprocal of the classical orbit period:

The significance of the Bohr model is that the laws of classical mechanics apply to the motion of the electron about the nucleus only when restricted by a quantum rule. Although rule 3 is not

completely well defined for small orbits, because the emission process involves two orbits with two different periods, Bohr could determine the energy spacing between levels using rule 3 and come to an exactly correct quantum rule: the angular momentum L is restricted to be an integer multiple of a fixed unit:

$$L = n \frac{h}{2\pi} = n\hbar$$

where $n = 1, 2, 3, \dots$ is called the principal quantum number, and $\hbar = h/2\pi$. The lowest value of n is 1; this gives a smallest possible orbital radius of 0.0529 nm known as the Bohr radius. Once an electron is in this lowest orbit, it can get no closer to the proton. Starting from the angular momentum quantum rule, Bohr was able to calculate the energies of the allowed orbits of the hydrogen atom and other hydrogen-like atoms and ions. Other points are:

1. Like Einstein's theory of the Photoelectric effect, Bohr's formula assumes that during a quantum jump a discrete amount of energy is radiated. However, unlike Einstein, Bohr stuck to the classical Maxwell theory of the electromagnetic field. Quantization of the electromagnetic field was explained by the discreteness of the atomic energy levels; Bohr did not believe in the existence of photons.
2. According to the Maxwell theory the frequency ν of classical radiation is equal to the rotation frequency ν_{rot} of the electron in its orbit, with harmonics at integer multiples of this frequency. This result is obtained from the Bohr model for jumps between energy levels E_n and E_{n-k} when k is much smaller than n . These jumps reproduce the frequency of the k -th harmonic of orbit n . For sufficiently large values of n (so-called Rydberg states), the two orbits involved in the emission process have nearly the same rotation frequency, so that the classical orbital frequency is not ambiguous. But for small n (or large k), the radiation frequency has no unambiguous classical interpretation. This marks the birth of the correspondence principle, requiring quantum theory to agree with the classical theory only in the limit of large quantum numbers.
3. The Bohr-Kramers-Slater theory (BKS theory) is a failed attempt to extend the Bohr model which violates the conservation of energy and momentum in quantum jumps, with the conservation laws only holding on average. Bohr's condition, that the angular momentum is

an integer multiple of \hbar was later reinterpreted in 1924 by de Broglie as a standing wave condition: the electron is described by a wave and a whole number of wavelengths must fit along the circumference of the electron's orbit:

$$n\lambda = 2\pi r.$$

Substituting de Broglie's wavelength of h/p reproduces Bohr's rule. In 1913, however, Bohr justified his rule by appealing to the correspondence principle, without providing any sort of wave interpretation. In 1913, the wave behavior of matter particles such as the electron (i.e., matter waves) was not suspected.

Modern concept of atomic model (De- Broglie's atomic model)

In 1925 a new kind of mechanics was proposed, quantum mechanics, in which Bohr's model of electrons traveling in quantized orbits was extended into a more accurate model of electron motion. The new theory was proposed by Werner Heisenberg. Another form of the same theory, wave mechanics, was discovered by the Austrian physicist Erwin Schrödinger independently, and by different reasoning. Schrödinger employed de Broglie's matter waves, but sought wave solutions of a three-dimensional wave equation describing electrons that were constrained to move about the nucleus of a hydrogen-like atom, by being trapped by the potential of the positive nuclear charge.

The shapes of atomic orbitals can be understood qualitatively by considering the analogous case of standing waves on a circular drum. To see the analogy, the mean vibrational displacement of each bit of drum membrane from the equilibrium point over many cycles (a measure of average drum membrane velocity and momentum at that point) must be considered relative to that point's distance from the center of the drum head. If this displacement is taken as being analogous to the probability of finding an electron at a given distance from the nucleus, then it will be seen that the many modes of the vibrating disk form patterns that trace the various shapes of atomic orbitals. The basic reason for this correspondence lies in the fact that the distribution of kinetic energy and momentum in a matter-wave is predictive of where the particle associated with the wave will be. That is, the probability of finding an electron at a given place is also a function of

the electron's average momentum at that point, since high electron momentum at a given position tends to "localize" the electron in that position, via the properties of electron wave-packets (see the Heisenberg uncertainty principle for details of the mechanism).

This relationship means that certain key features can be observed in both drum membrane modes and atomic orbitals. For example, in all of the modes analogous to s orbitals (the top row in the animated illustration below), it can be seen that the very center of the drum membrane vibrates most strongly, corresponding to the antinode in all s orbitals in an atom. This antinode means the electron is most likely to be at the physical position of the nucleus (which it passes straight through without scattering or striking it), since it is moving (on average) most rapidly at that point, giving it maximal momentum.

A mental "planetary orbit" picture closest to the behavior of electrons in s orbitals, all of which have no angular momentum, might perhaps be that of a Keplerian orbit with the orbital eccentricity of 1 but a finite major axis, not physically possible (because particles were to collide), but can be imagined as a limit of orbits with equal major axes but increasing eccentricity.

Below, a number of drum membrane vibration modes are shown. The analogous wave functions of the hydrogen atom are indicated. A correspondence can be considered where the wave functions of a vibrating drum head are for a two-coordinate system $\psi(r, \theta)$ and the wave functions for a vibrating sphere are three-coordinate $\psi(r, \theta, \phi)$.

Atomic bonding in solids

Primary Inter-atomic Bonds

Ionic Bonding

This is the bond when one of the atoms is negative (has an extra electron) and another is positive (has lost an electron). Then there is a strong, direct Coulomb attraction. An example is NaCl. In the molecule, there are more electrons around Cl, forming Cl⁻ and less around Na, forming Na⁺. Ionic bonds are the strongest bonds. In real solids, ionic bonding is usually combined with covalent bonding.

Covalent Bonding

In covalent bonding, electrons are shared between the molecules, to saturate the valency. The simplest example is the H₂ molecule, where the electrons spend more time in between the nuclei than outside, thus producing bonding.

Metallic Bonding

In metals, the atoms are ionized, losing some electrons from the valence band. Those electrons form an *electron sea*, which binds the charged nuclei in place, in a similar way that the electrons in between the H atoms in the H₂ molecule bind the protons.

Secondary Bonding (Van der Waals)

Fluctuating Induced Dipole Bonds

Since the electrons may be on one side of the atom or the other, a dipole is formed: the + nucleus at the center, and the electron outside. Since the electron moves, the dipole fluctuates. This fluctuation in atom A produces a fluctuating electric field that is felt by the electrons of an adjacent atom, B. Atom B then polarizes so that its outer electrons are on the side of the atom closest to the + side (or opposite to the – side) of the dipole in A. This bond is called van der Waals bonding.

Polar Molecule-Induced Dipole Bonds

A polar molecule like H₂O (Hs are partially +, O is partially -), will induce a dipole in a nearby atom, leading to bonding.

Permanent Dipole Bonds

This is the case of the hydrogen bond in ice. The H end of the molecule is positively charged and can bond to the negative side of another dipolar molecule, like the O side of the H₂O dipole

Crystallography

Crystal Structures:

Atoms self-organize in *crystals*, most of the time. The crystalline lattice is a periodic array of the atoms. When the solid is not crystalline, it is called amorphous. Examples of crystalline solids

are metals, diamond and other precious stones, ice, graphite. Examples of amorphous solids are glass, amorphous carbon (a-C), amorphous Si, most plastics To discuss crystalline structures it is useful to consider atoms as being hard spheres, with well-defined radii. In this scheme, the shortest distance between two like atoms is one diameter.

Crystal Lattice is used to represent a three-dimensional periodic array of points coinciding with atom positions.

Unit cell is smallest repeatable entity that can be used to completely represent a crystal structure. It is the building block of crystal structure.

Bravais lattices

When the crystal systems are combined with the various possible lattice centerings, we arrive at the Bravais lattices. They describe the geometric arrangement of the lattice points, and thereby the translational symmetry of the crystal. In three dimensions, there are 14 unique Bravais lattices that are distinct from one another in the translational symmetry they contain. All crystalline materials recognized until now (not including quasicrystals) fit in one of these arrangements. The fourteen three-dimensional lattices, classified by crystal system, are shown above. The Bravais lattices are sometimes referred to as space lattices.

The crystal structure consists of the same group of atoms, the basis, positioned around each and every lattice point. This group of atoms therefore repeats indefinitely in three dimensions according to the arrangement of one of the 14 Bravais lattices. The characteristic rotation and mirror symmetries of the group of atoms, or unit cell, is described by its crystallographic point group.

Metallic Crystal Structures

Important properties of the unit cells are



The type of atoms and their radii R .



Cell dimensions (side a in cubic cells, side of base a and height c in HCP) in terms of R .



n , number of atoms per unit cell. For an atom that is shared with m adjacent unit cells, only count a fraction of the atom, $1/m$.

 **CN**, the coordination number, which is the number of closest neighbors to which an atom is bonded.

 **APF**, the atomic packing factor, which is the fraction of the volume of the cell actually occupied by the hard spheres. $APF = \text{Sum of atomic volumes} / \text{Volume of cell}$.

Crystalline and Non-crystalline materials:

Single Crystals

Crystals can be *single crystals* where the whole solid is one crystal. Then it has a regular geometric structure with flat faces.

Polycrystalline Materials

A solid can be composed of many crystalline grains, not aligned with each other. It is called *polycrystalline*. The grains can be more or less aligned with respect to each other. Where they meet is called a *grain boundary*.









Non-Crystalline Solids

In amorphous solids, there is no long-range order. But amorphous does not mean random, since the distance between atoms cannot be smaller than the size of the hard spheres. Also, in many cases there is some form of short-range order. For instance, the tetragonal order of crystalline SiO_2 (quartz) is still apparent in amorphous SiO_2 (silica glass.)

Unit Cell	n	CN	a/R	APF
SC	1	6	2	0.52
BCC	2	8	$4\sqrt{3}$	0.68
FCC	4	12	$2\sqrt{2}$	0.74
HCP	6	12		0.74

Miller Indices: A system of notation is required to identify particular direction(s) or plane(s) to characterize the arrangement of atoms in a unit cell

Rules for Miller Indices (Planes)

-  Determine the intercepts of the face along the crystallographic axes, *in terms of unit & dimensions.*
-  Take the reciprocals
-  Clear fractions
-  Reduce to lowest terms
-  For example, if the x-, y-, and z- intercepts are 2, 1, and 3, the Miller indices are calculated as:
-  Take reciprocals: $1/2, 1/1, 1/3$
-  Clear fractions (multiply by 6): 3, 6, 2
-  Reduce to lowest terms (already there)

Thus, the Miller indices are 3,6,2. If a plane is parallel to an axis, its intercept is at infinity and its Miller index is zero. A generic Miller index is denoted by (hkl) . A family of planes is represented by $\{hkl\}$ If a plane has negative intercept, the negative number is denoted by a bar above the number. *Never alter negative numbers.* For example, do not divide -1, -1, -1 by -1 to get 1,1,1. This implies symmetry that the crystal may not have!

Miller Indices - Direction

- A vector of convenient length is placed parallel to the required direction
- The length of the vector projection on each of three axes are measured in terms of unit cell dimensions
- These three numbers are made to smallest integer values, known as indices, by multiplying or dividing by a common factor
- The three indices are enclosed in square brackets, $[uvw]$.
- A family of directions is represented by $\langle uvw \rangle$

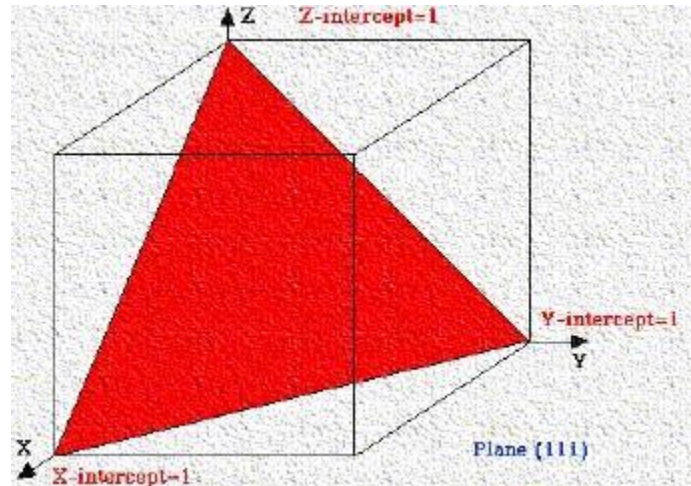

Some General Principles

- If a Miller index is zero, the plane is parallel to that axis.
- The smaller a Miller index, the more nearly parallel the plane is to the axis.
- The larger a Miller index, the more nearly perpendicular a plane is to that axis.
- Multiplying or dividing a Miller index by a constant has no effect on the orientation of the plane
- Miller indices are almost always small.

Why Miller Indices?

- Using reciprocals spares us the complication of infinite intercepts.
- Formulas involving Miller indices are very similar to related formulas from analytical geometry.
- Specifying dimensions in unit cell terms means that the same label can be applied to any face with a similar stacking pattern, regardless of the crystal class of the crystal. Face 111 always steps the same way regardless of crystal system.

Schematic Unit Cells

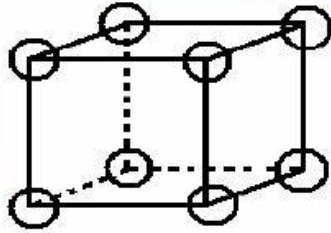

Simple Cubic

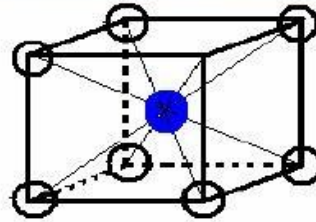

Body Centered Cubic

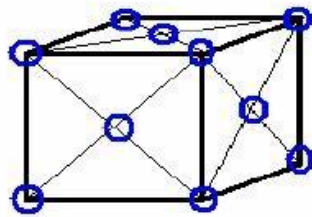

Face Centered Cubic

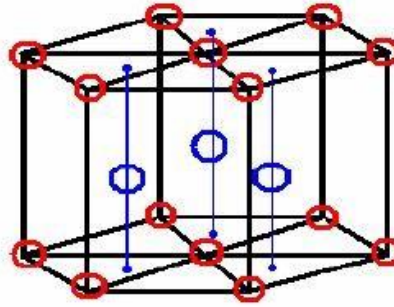

Hexagonal Close Packed

Imperfections in Solids

Point Defects

Vacancies and Self-Interstitials

A **vacancy** is a lattice position that is vacant because the atom is missing. It is created when the solid is formed. There are other ways of making a vacancy, but they also occur naturally as a result of thermal vibrations.

An **interstitial** is an atom that occupies a place outside the normal lattice position. It may be the same type of atom as the others (self interstitial) or an impurity atom. In the case of vacancies and interstitials, there is a change in the coordination of atoms around the defect. This means that the forces are not balanced in the same way as for other atoms in the solid, which results in lattice distortion around the defect. A high temperature is needed to have a high *thermal* concentration of vacancies.

Frenkel-defect is a vacancy-interstitial pair of cations

Schottky-defect is a pair of nearby cation and anion vacancies

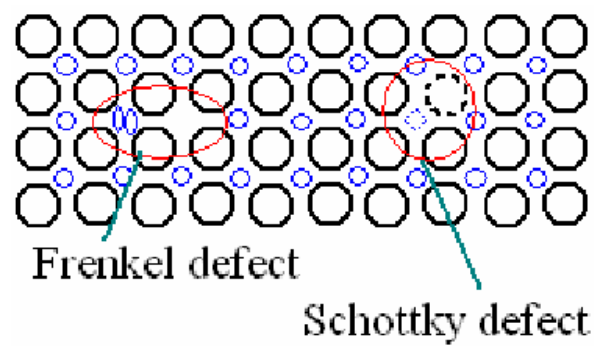

Theoretical yield point

Theoretical yield is the maximum quantity of a product that could be formed in a chemical reaction if all the limiting reactant reacted to form products (distinguished from actual yield).

Dislocations—Linear Defects

Dislocations are abrupt changes in the regular ordering of atoms, along a line (dislocation line) in the solid. They occur in high density and are very important in mechanical properties of material. They are characterized by the Burgers vector, found by doing a loop around the dislocation line and noticing the extra inter atomic spacing needed to close the loop. The Burgers vector in metals points in a close packed direction.

Line Defects

- Line defects or Dislocations are abrupt change in atomic order along a line.
- They occur if an incomplete plane inserted between perfect planes of atoms or when vacancies are aligned in a line.
- A dislocation is the defect responsible for the phenomenon of slip, by which most metals deform plastically.
- Dislocations occur in high densities (10^8 - 10^{10} m^{-2}), and are intimately connected to almost all mechanical properties which are in fact structure-sensitive.

- Dislocation form during plastic deformation, solidification or due to thermal stresses arising from rapid cooling.

Line Defects – Burger’s Vector

- A dislocation is characterized by Burger’s vector, b .
- It is unique to a dislocation, and usually has the direction of close packed lattice direction. It is also the slip direction of a dislocation.
- It represents the magnitude and direction of distortion associated with that particular dislocation.
- Two limiting cases of dislocations, edge and screw, are characterized by Burger’s vector perpendicular to the dislocation line (t) and Burger’s vector parallel to the dislocation line respectively. Ordinary dislocation is of mixed character of edge and screw type.

Edge dislocations occur when an extra plane is inserted. The dislocation line is at the end of the plane. In an edge dislocation, the Burgers vector is perpendicular to the dislocation line.

Line Defects – Edge Dislocation

- It is also called as Taylor-Orowan dislocation.
- It will have regions of compressive and tensile stresses on either side of the plane containing dislocation.

Screw dislocations result when displacing planes relative to each other through shear. In this case, the Burgers vector is parallel to the dislocation line.

Line Defects – Screw Dislocation

- It is also called as Burger’s dislocation.
- It will have regions of shear stress around the dislocation line
- For positive screw dislocation, dislocation line direction is parallel to Burger’s vector, and vice versa.

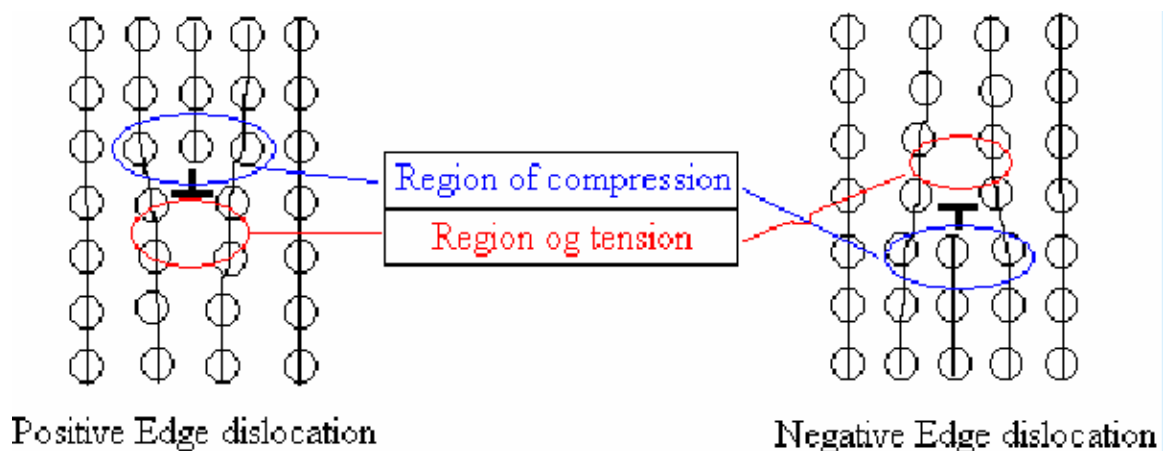
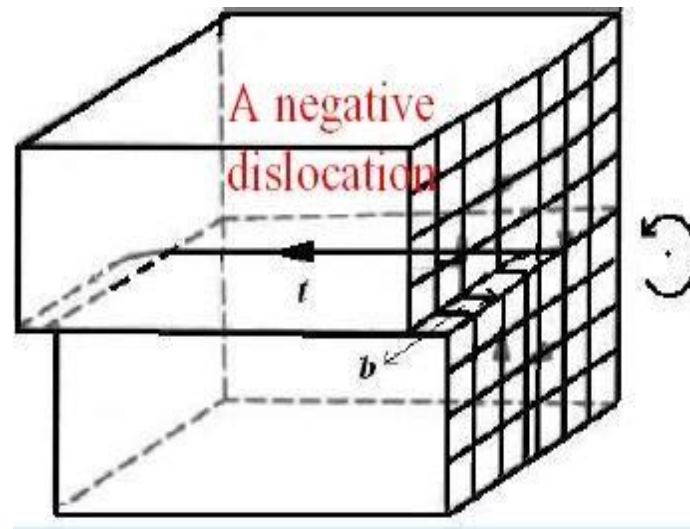

Interfacial Defects:

The environment of an atom at a surface differs from that of an atom in the bulk, in that the number of neighbors (coordination) decreases. This introduces unbalanced forces which result in *relaxation* (the lattice spacing is decreased) or *reconstruction* (the crystal structure changes). The density of atoms in the region including the grain boundary is smaller than the bulk value, since void space occurs in the interface. Surfaces and interfaces are very reactive and it is usual that impurities segregate there. Since energy is required to form a surface, grains tend to grow in size at the expense of smaller grains to minimize energy. This occurs by diffusion, which is accelerated at high temperatures.

Interfacial Defects

- An interfacial defect is a 2-D imperfection in crystalline solids, and have different crystallographic orientations on either side of it.
- Region of distortion is about few atomic distances.
- They usually arise from clustering of line defects into a plane.
- These imperfections are not thermodynamically stable, but meta-stable in nature.
- E.g.: External surface, Grain boundaries, Stacking faults, Twin boundaries, Phase boundaries.

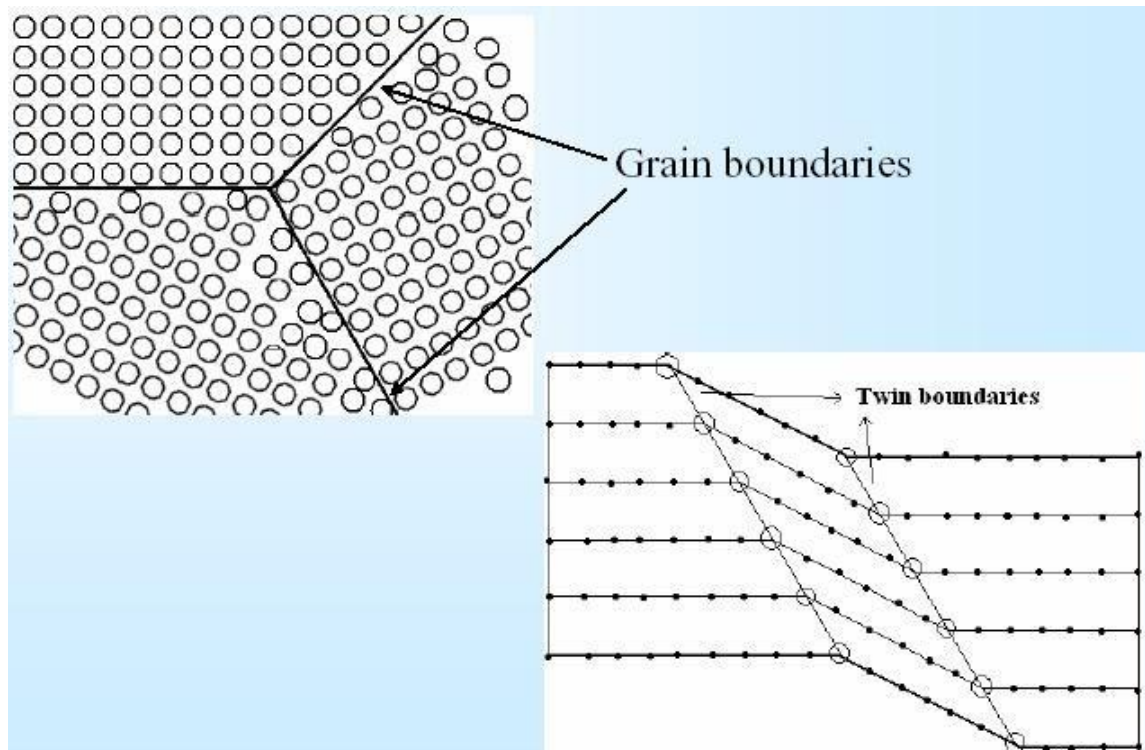

Bulk or Volume Defects :

Other defects exist in all solid materials that are much larger than those heretofore discussed. A typical volume defect is porosity, often introduced in the solid during processing. A common example is snow, which is highly porous ice.

Bulk or Volume Defects

Volume defects are three-dimensional in nature. These defects are introduced, usually, during processing and fabrication operations like casting, forming etc. E.g.: Pores, Cracks, Foreign particles. These defects act like stress raisers, thus deleterious to mechanical properties of parent solids. In some instances, foreign particles are added to strengthen the solid – dispersion hardening. Particles added are hindrances to movement of dislocations which have to cut through or bypass the particles thus increasing the strength.

X-RAY DIFFRACTION: DETERMINATION OF CRYSTAL STRUCTURES

Diffraction occurs when a wave encounters a series of regularly spaced obstacles that (1) are capable of scattering the wave, and (2) have spacings that are comparable in magnitude to the wavelength. Furthermore, diffraction is a consequence of specific phase relationships established between two or more waves that have been scattered by the obstacles.

Bragg's Law of X-ray Diffraction

In 1912, Laue suggested that a crystal which consisted of a three-dimensional array of regularly spaced atoms could serve as a grating. The crystal differs from the ordinary grating in the sense that the diffracting centres in the crystal are not in one plane, i.e. crystal acts as a space grating rather than plane grating used for the study of light diffraction.

On the suggestion of Laue, his associates succeeded in diffracting X-rays by passing them through a thin crystal of Zinc blende. The diffraction pattern obtained by them consists of a central spot and a series of spots arranged in a definite pattern around the central spot. This symmetrical pattern of spots is known as Laue pattern. The explanation for this was given by Bragg. According to Bragg, the spots are produced due to the reflection of some of the incident X-rays from the various sets of parallel crystal planes (called as Bragg's planes), which contain a large number of atoms.

Consider a ray PA reflected at atom A in the direction AR from plane I and another ray QB reflected at another atom B in the direction BS (Fig. 3.63). Now, draw two perpendiculars AC and AD from the atom A on QB and BS respectively. The two reflected rays AR and BS will be in phase or out of phase depending on the path difference. When the path difference, $CB + BD$ is a whole wavelength λ , or multiple of whole wavelength ($n\lambda$), then the two rays will reinforce each other and produce an intense spot due to constructive interference. Obviously, the condition of reinforcement, i.e. constructive interference is:

$$\begin{aligned} CB + BD &= n\lambda \\ CB = BD &= d \sin \theta \end{aligned}$$

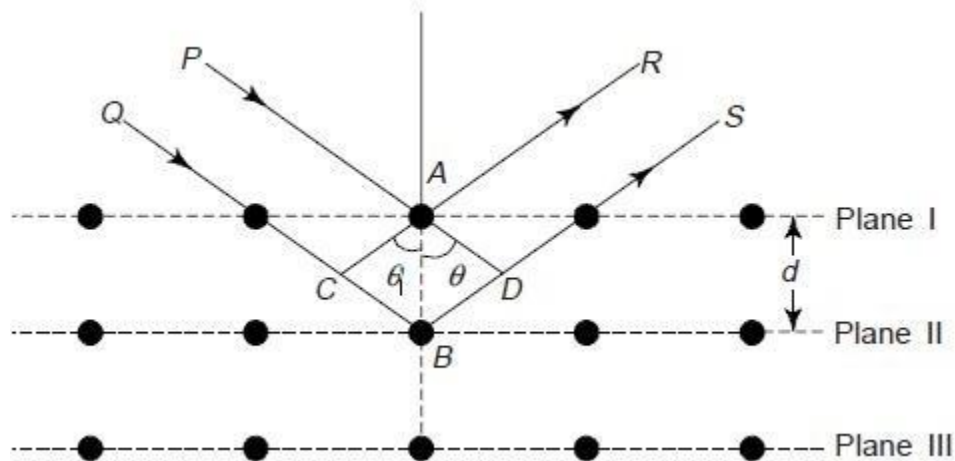

where, θ is the angle between the incident ray and the planes of reflection and called as *glancing angle*. Therefore, we have

$$2d \sin \theta = n\lambda \quad (11)$$

where d is the interplanar spacing of planes, i.e. distance between the same set of planes and $n = 1, 2, 3, \dots$ stand for first order, second order, third order maxima respectively. Equation (11) is known as Bragg's law. We must note that the Bragg's reflection can occur only for $\lambda \leq 2d$.

The directions along which the maxima are observed can be obtained from Bragg's law, by giving different values of θ , i.e.,

$$\text{for first maximum,} \quad \sin \theta_1 = \frac{\lambda}{2d}$$

$$\text{for second maximum,} \quad \sin \theta_2 = \frac{2\lambda}{2d}$$

$$\text{for third maximum,} \quad \sin \theta_3 = \frac{3\lambda}{2d} \text{ and so on.}$$

As the order of spectrum increases, the intensity goes on decreasing.

We must note that the Bragg equation is not limited to atomic planes parallel to the crystal surface. Sets of parallel atomic planes can be constructed through the crystal at different angles. The value of the grating space d is different for each set of parallel planes.

The magnitude of the distance between two adjacent and parallel planes of atoms (i.e., the interplanar spacing) is a function of the Miller indices (h, k, l) as well as the lattice parameter(s). For example, for crystal structures that have cubic symmetry

$$d_{hkl} = \frac{a}{\sqrt{h^2 + k^2 + l^2}}$$

MODULE –II

Mechanical Properties of Metals

Stress-Strain curve (Mild Steel)

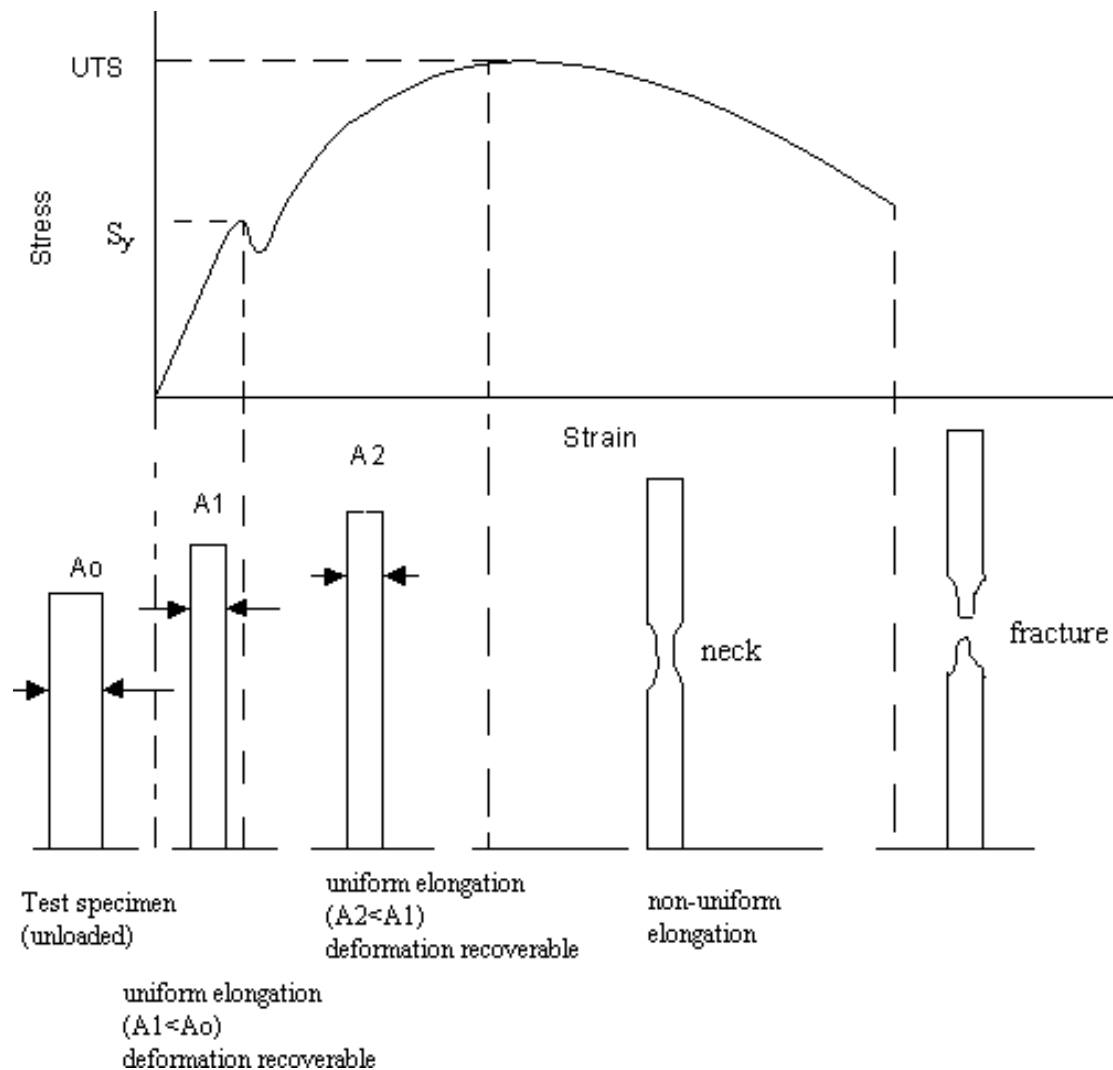

Elastic deformation:

When the stress is removed, the material returns to the dimension it had before the load was applied. Valid for small strains (except the case of rubbers). Deformation is *reversible, non permanent*

Plastic deformation:

When the stress is removed, the material does not return to its previous dimension but there is a *permanent*, irreversible deformation. In tensile tests, if the deformation is *elastic*, the stress-strain relationship is called Hooke's law:

$$\sigma = E \varepsilon$$

That is, E is the slope of the stress-strain curve. E is *Young's modulus* or *modulus of elasticity*. In some cases, the relationship is not linear so that E can be defined alternatively as the local slope:

$$E = d\sigma/d\varepsilon$$

Shear stresses produce strains according to:

$$\tau = G \gamma$$

where G is the *shear modulus*. Elastic moduli measure the *stiffness* of the material. They are related to the *second* derivative of the interatomic potential, or the first derivative of the force vs. inter nuclear distance. By examining these curves we can tell which material has a higher modulus. Due to thermal vibrations the elastic modulus decreases with temperature. E is large for ceramics (stronger ionic bond) and small for polymers (weak covalent bond). Since the interatomic distances depend on direction in the crystal, E depends on direction (i.e., it is anisotropic) for single crystals. For *randomly* oriented polycrystals, E is isotropic.

Yield criteria and macroscopic aspects of plastic deformation

Gross plastic deformation of a polycrystalline specimen corresponds to the comparable distortion of the individual grains by means of slip. During deformation, mechanical integrity and coherency are maintained along the grain boundaries; that is, the grain boundaries is constrained, to some degree, in the shape it may assume by its neighboring grains. Before deformation the grains are equiaxed, or have approximately the same dimension in all directions. For this particular deformation, the grains become elongated along the directions. For this particular deformation, the grains become elongated along the direction in which the specimen was extended.

Tensile Properties

Yield point. If the stress is too large, the strain deviates from being proportional to the stress. The point at which this happens is the *yield point* because there the material yields, deforming permanently (plastically).

Yield stress. Hooke's law is not valid beyond the yield point. The stress at the yield point is called *yield stress*, and is an important measure of the mechanical properties of materials. In practice, the yield stress is chosen as that causing a permanent strain of 0.002 *The yield stress measures the resistance to plastic deformation.* The reason for plastic deformation, in normal materials, is not that the atomic bond is stretched beyond repair, but the motion of dislocations, which involves breaking and reforming bonds. *Plastic deformation is caused by the motion of dislocations.*

Tensile strength: When stress continues in the plastic regime, the stress-strain passes through a maximum, called the *tensile strength*, and then falls as the material starts to develop a *neck* and it finally breaks at the *fracture point*.

For structural applications, the yield stress is usually a more important property than the tensile strength, since once it is passed, the structure has deformed beyond acceptable limits.

Ductility: The ability to deform before braking. It is the opposite of **brittleness**. Ductility can be given either as percent maximum elongation \hat{a}_{\max} or maximum area reduction.

$$\%EL = \hat{a}_{\max} \times 100 \%$$

$$\%AR = (A_0 - A_f)/A_0$$

These are measured after fracture (repositioning the two pieces back together).

Resilience: Capacity to absorb energy *elastically*. The energy per unit volume is the *area under the strain-stress curve in the elastic region*.

Toughness: Ability to absorb energy up to fracture. The energy per unit volume is the *total area under the strain-stress curve*. It is measured by an impact test .

True Stress and Strain

When one applies a constant tensile force the material will break after reaching the tensile strength. The material starts necking (the transverse area decreases) but the stress cannot increase beyond tensile strength. The ratio of the force to the initial area, what we normally do, is called the engineering stress. If the ratio is to the actual area (that changes with stress) one obtains the *true stress*.

Yield criteria and macroscopic aspects of plastic deformation

Gross plastic deformation of a polycrystalline specimen corresponds to the comparable distortion of the individual grains by means of slip. During deformation, mechanical integrity and coherency are maintained along the grain boundaries; that is, the grain boundaries is constrained, to some degree, in the shape it may assume by its neighboring grains. Before deformation the grains are equiaxed, or have approximately the same dimension in all directions. For this particular deformation, the grains become elongated along the directions. For this particular deformation, the grains become elongated along the direction in which the specimen was extended.

Mohs Hardness Scale

The Mohs hardness scale for minerals has been used since 1822. It simply consists of 10 minerals arranged in order from 1 to 10. Diamond is rated as the hardest and is indexed as 10; talc as the softest with index number 1. Each mineral in the scale will scratch all those below it as follows:

Diamond	10
Corundum	9
Topaz	8
Quartz	7
Orthoclase (Feldspar)	6

Apatite	5
Fluorite	4
Calcite	3
Gypsum	2
Talc	1

The Brinell Hardness Test

The Brinell hardness test method consists of indenting the test material with a 10 mm diameter hardened steel or carbide ball subjected to a load of 3000 kg. For softer materials the load can be reduced to 1500 kg or 500 kg to avoid excessive indentation. The full load is normally applied for 10 to 15 seconds in the case of iron and steel and for at least 30 seconds in the case of other metals. The diameter of the indentation left in the test material is measured with a low powered microscope. The Brinell hardness number is calculated by dividing the load applied by the surface area of the indentation.

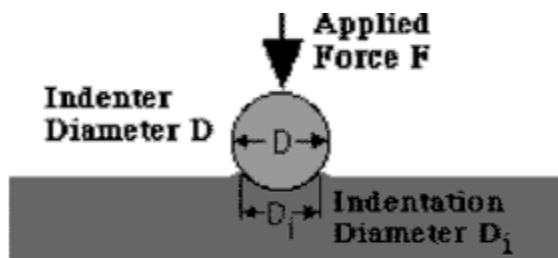

$$\text{BHN} = \frac{F}{\frac{\pi}{2} D \cdot (D - \sqrt{D^2 - D_i^2})}$$

Rockwell Hardness Test

The Rockwell hardness test method consists of indenting the test material with a diamond cone or hardened steel ball indenter. The indenter is forced into the test material under a preliminary minor load F_0 (Fig. 1A) usually 10 kgf. When equilibrium has been reached, an indicating device, which follows the movements of the indenter and so responds to changes in depth of penetration of the indenter is set to a datum position. While the preliminary minor load is still applied an additional major load is applied with resulting increase in penetration (Fig. 1B). When equilibrium has again been reached, the additional major load is removed but the preliminary minor load is still maintained. Removal of the additional major load allows a partial recovery, so

reducing the depth of penetration. The permanent increase in depth of penetration, resulting from the application and removal of the additional major load is used to calculate the Rockwell hardness number. Advantages of the Rockwell hardness method include the direct Rockwell hardness number readout and rapid testing time.

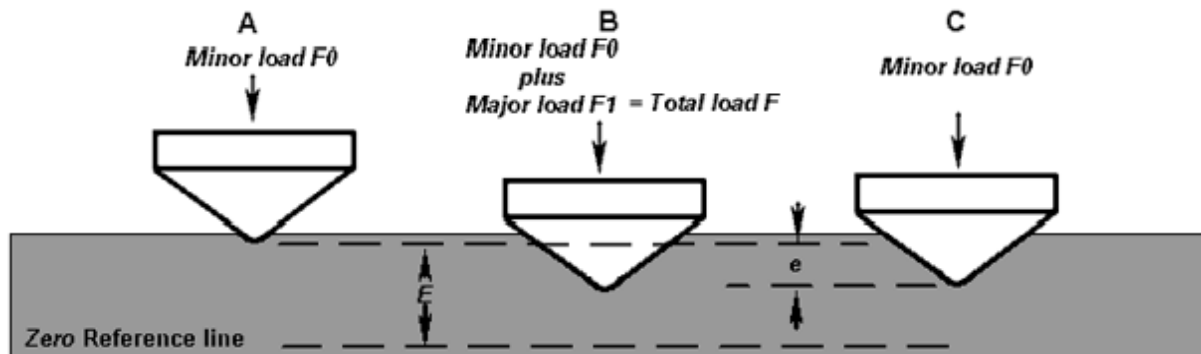

Vickers Hardness Test

The Vickers hardness test method consists of indenting the test material with a diamond indenter, in the form of a right pyramid with a square base and an angle of 136 degrees between opposite faces subjected to a load of 1 to 100 kgf. The full load is normally applied for 10 to 15 seconds. The two diagonals of the indentation left in the surface of the material after removal of the load are measured using a microscope and their average calculated. The area of the sloping surface of the indentation is calculated. The Vickers hardness is the quotient obtained by dividing the kgf load by the square mm area of indentation.

When the mean diagonal of the indentation has been determined the Vickers hardness may be calculated from the formula, but is more convenient to use conversion tables. The Vickers hardness should be reported like 800 HV/10, which means a Vickers hardness of 800, was obtained using a 10 kgf force. Several different loading settings give practically identical hardness numbers on uniform material, which is much better than the arbitrary changing of scale with the other hardness testing methods. The advantages of the Vickers hardness test are that extremely accurate readings can be taken, and just one type of indenter is used for all types of metals and surface treatments. Although thoroughly adaptable and very precise for testing the

softest and hardest of materials, under varying loads, the Vickers machine is a floor standing unit that is more expensive than the Brinell or Rockwell machines.

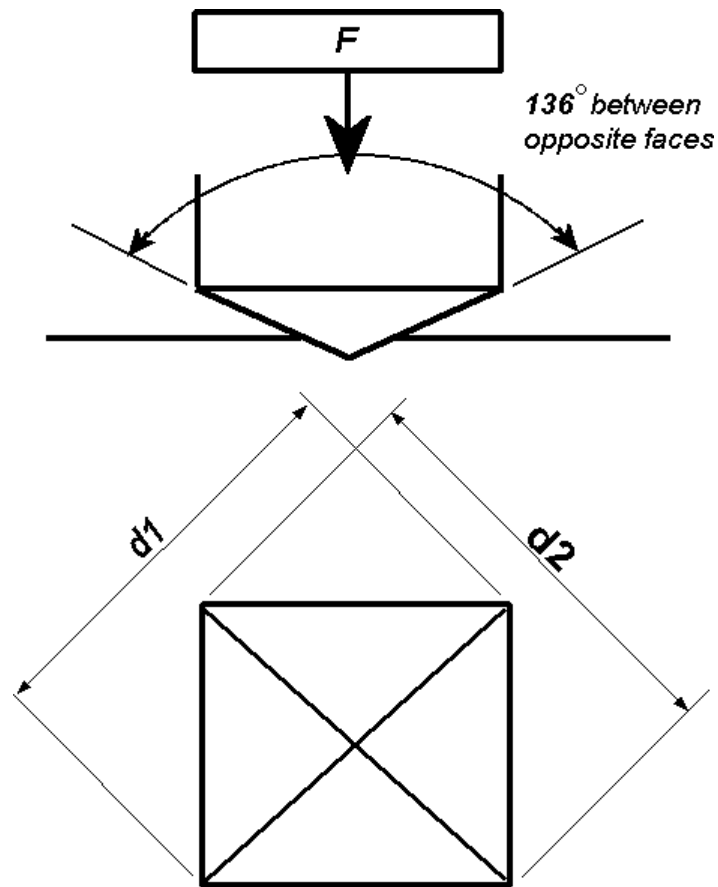

F = Load in kgf

D = Arithmetic mean of the two diagonals, d_1 and d_2 in mm

HV = Vickers hardness

$$HV = \frac{2F \sin \frac{136^\circ}{2}}{d^2} \quad HV = 1.854 \frac{F}{d^2} \text{ approximately}$$

Micro-hardness Test

Knoop Hardness Test

The term microhardness test usually refers to static indentations made with loads not exceeding 1 kgf. The indenter is either the Vickers diamond pyramid or the Knoop elongated diamond pyramid. The procedure for testing is very similar to that of the standard Vickers hardness test, except that it is done on a microscopic scale with higher precision instruments. The surface being tested generally requires a metallographic finish; the smaller the load used, the higher the surface finish required. Precision microscopes are used to measure the indentations; these usually have a magnification of around X500 and measure to an accuracy of ± 0.5 micrometres. Also with the same observer differences of ± 0.2 micrometres can usually be resolved. It should, however, be added that considerable care and experience are necessary to obtain this accuracy.

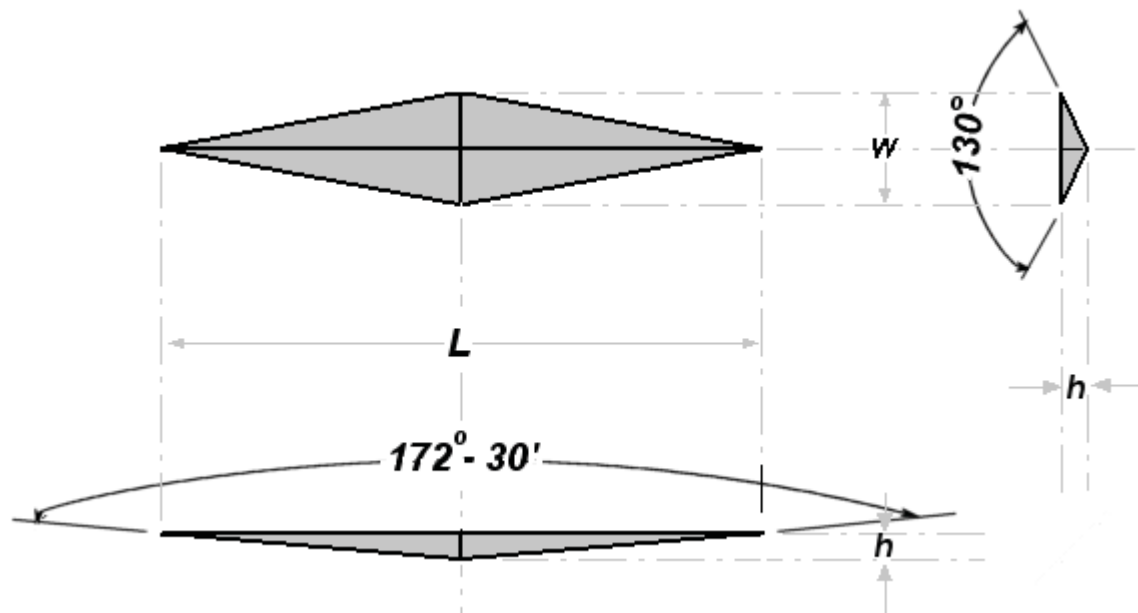

The Knoop hardness number KHN is the ratio of the load applied to the indenter, P (kgf) to the unrecovered projected area A (mm^2)

$$KHN = F/A = P/CL^2$$

Where:

F = applied load in kgf

A = the unrecovered projected area of the indentation in mm^2

L = measured length of long diagonal of indentation in mm

$C = 0.07028$ = Constant of indenter relating projected area of the indentation to the square of the length of the long diagonal.

The Scleroscope Hardness Test

The Scleroscope test consists of dropping a diamond tipped hammer, which falls inside a glass tube under the force of its own weight from a fixed height, onto the test specimen. The height of the rebound travel of the hammer is measured on a graduated scale. The scale of the rebound is arbitrarily chosen and consists on Shore units, divided into 100 parts, which represent the average rebound from pure hardened high-carbon steel. The scale is continued higher than 100 to include metals having greater hardness. In normal use the shore scleroscope test does not mark the material under test. The Shore Scleroscope measures hardness in terms of the elasticity of the material and the hardness number depends on the height to which the hammer rebounds, the harder the material, the higher the rebound. Advantages of this method are portability and non-marking of the test surface.

The Durometer

The Durometer is a popular instrument for measuring the indentation hardness of rubber and rubber-like materials. The most popular testers are the Model A used for measuring softer materials and the Model D for harder materials. The operation of the tester is quite simple. The material is subjected to a definite pressure applied by a calibrated spring to an indenter that is either a cone or sphere and an indicating device measures the depth of indentation.

Failure

Fundamentals of Fracture

Fracture is a form of failure where the material separates in pieces due to stress, at temperatures below the melting point. The fracture is termed ductile or brittle depending on whether the elongation is large or small. Steps in fracture (response to stress):

- Crack formation
- Crack propagation

Ductile Fracture

Stages of ductile fracture

- Initial necking
 - Small cavity formation (micro voids)
 - Void growth (ellipsoid) by coalescence into a crack
 - Fast crack propagation around neck. Shear strain at 45°
 - Final shear fracture (cup and cone)

The interior surface is fibrous, irregular, which signify plastic deformation.

Brittle Fracture

There is no appreciable deformation, and crack propagation is very fast. In most brittle materials, crack propagation (by bond breaking) is along specific crystallographic planes (*cleavage* planes). This type of fracture is transgranular (through grains) producing grainy texture (or faceted texture) when cleavage direction changes from grain to grain. In some materials, fracture is intergranular.

Fracture occurs due to *stress concentration* at flaws, like surface scratches, voids,

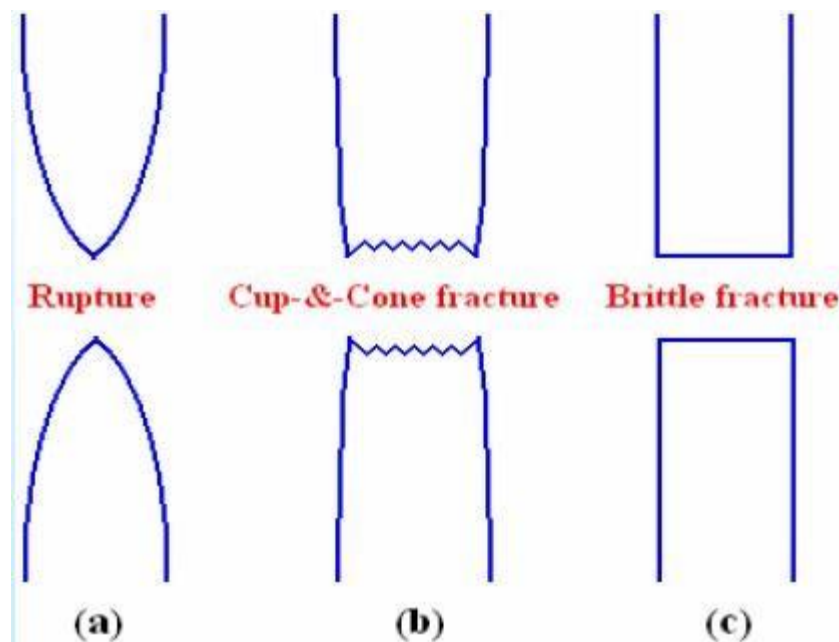

Parameter	Ductile fracture	Brittle fracture
Strain energy required	Higher	Lower
Stress, during cracking	Increasing	Constant
Crack propagation	Slow	Fast
Warning sign	Plastic deformation	None
Deformation	Extensive	Little
Necking	Yes	No
Fractured surface	Rough and dull	Smooth and bright
Type of materials	Most metals (not too cold)	Ceramics, Glasses, Ice

Impact Fracture:

Impact fractures can best be described as a flute or strip of material that was cleanly sheared from a projectile point. The most common type of impact fracture starts at the tip of a point and runs down one blade edge possibly reaching the shoulder of a point. Some points were reworked into a useable point after having been damaged by an impact fracture. Normalized tests, like the Charpy and Izod tests measure the *impact energy* required to fracture a notched specimen with a hammer mounted on a pendulum. The energy is measured by the change in potential energy (height) of the pendulum. This energy is called ***notch toughness***.

Ductile brittle transition

Ductile to brittle transition occurs in materials when the temperature is dropped below a *transition temperature*. Alloying usually increases the ductile-brittle transition temperature, for ceramics, this type of transition occurs at much higher temperatures than for metals.

The notched-bar impact test can be used to determine whether or not a material experiences a ductile-to-brittle transition as the temperature is decreased. In such a transition, at higher temperatures the impact energy is relatively large since the fracture is ductile. As the temperature

is lowered, the impact energy drops over a narrow temperature range as the fracture becomes more brittle.

The transition can also be observed from the fracture surfaces, which appear fibrous or dull for totally ductile fracture, and granular and shiny for totally brittle fracture. Over the ductile-to-brittle transition features of both types will exist.

While for pure materials the transition may occur very suddenly at a particular temperature, for many materials the transition occurs over a range of temperatures. This causes difficulties when trying to define a single transition temperature and no specific criterion has been established.

The ductile-brittle transition is exhibited in bcc metals, such as low carbon steel, which become brittle at low temperature or at very high strain rates. Fcc metals, however, generally remain ductile at low temperatures.

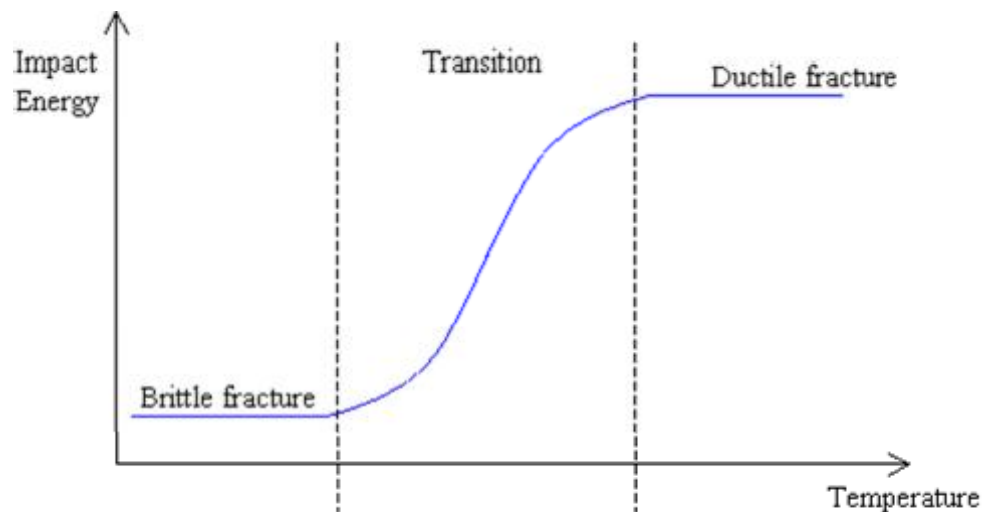

Fatigue:

Fatigue is the catastrophic failure due to dynamic (fluctuating) stresses. It can happen in bridges, airplanes, machine components, etc. The characteristics are:

- long period of cyclic strain
- the most usual (90%) of metallic failures (happens also in ceramics and polymers)
- is brittle-like even in ductile metals, with little plastic deformation
- it occurs in stages involving the initiation and propagation of cracks.

Cyclic Stresses

These are characterized by *maximum*, *minimum* and *mean stress*, the *stress amplitude*, and the *stress ratio*.

Crack Initiation and Propagation

Stages of fatigue failure:

- I. crack initiation at high stress points (stress raisers)
- II. propagation (incremental in each cycle)
- III. final failure by fracture

Stage I - propagation

- slow
- along crystallographic planes of high shear stress
- flat and featureless fatigue surface

Stage II - propagation

Crack propagates by repetitive plastic blunting and sharpening of the crack tip.

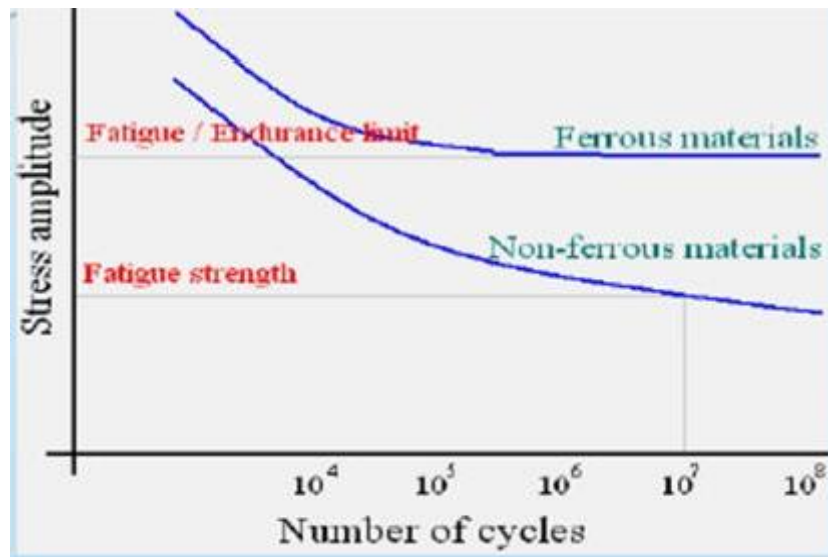

Creep

Creep is the time-varying plastic deformation of a material stressed at high temperatures. Examples: turbine blades, steam generators. Keys are the time dependence of the strain and the high temperature.

The Creep Curve

Creep in metals is defined as time dependent plastic deformation at constant stress (or load) and temperature. The form of a typical creep curve of strain versus time is in Figure. The slope of this curve is the **creep rate** $d\varepsilon/dt$. The curve may show the instantaneous elastic and plastic strain that occurs as the load is applied, followed by the plastic strain which occurs over time. Three stages to the creep curve may be identified:

Primary creep: in which the creep resistance increases with strain leading to a decreasing creep strain rate.

Secondary (Steady State) creep: in which there is a balance between work hardening and recovery processes, leading to a minimum constant creep rate.

Tertiary creep: in which there is an accelerating creep rate due to the accumulating damage, which leads to creep rupture, and which may only be seen at high temperatures and stresses and in constant load machines.

The minimum secondary creep rate is of most interest to design engineers, since failure avoidance is required and in this region some predictability is possible. In the USA two Standards are commonly used: (i) The stress to produce a creep rate of 0.0001% per hour (1% in 10,000 hours). (ii) The stress to produce a creep rate of 0.00001% per hour (1% in 100,000 hours or approximately 11.5 years). The first requirement would be typical of that for gas turbine blades, while the second for steam turbines. Constant load machines simulate real engineering situations more accurately, but as the specimen extends its cross section area reduces, leading to a rising stress. Machines designed to reduce the load to compensate for the reduced area and maintain constant stress may produce an extended steady state region.

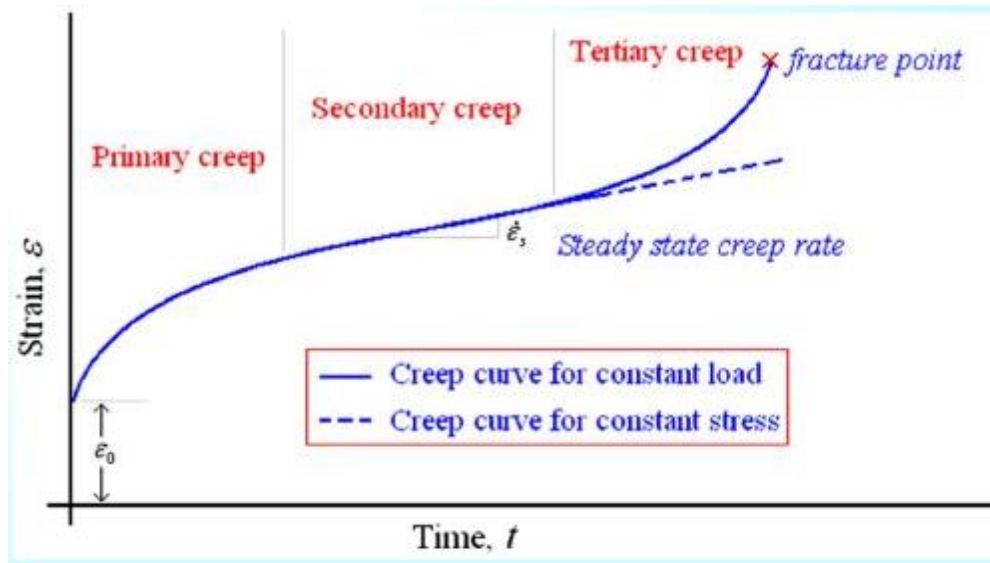

Stress and Temperature Effects

Both temperature and the level of the applied stress influence the creep characteristics. The results of creep rupture tests are most commonly presented as the logarithm of stress versus the logarithm of rupture lifetime. Creep becomes more pronounced at higher temperatures. There is essentially no creep at temperatures below 40% of the melting point. Creep increases at higher applied stresses. The behavior can be characterized by the following expression, where K , n and Q_c are constants for a given material:

$$d\varepsilon/dt = K \sigma^n \exp(-Q_c/RT)$$

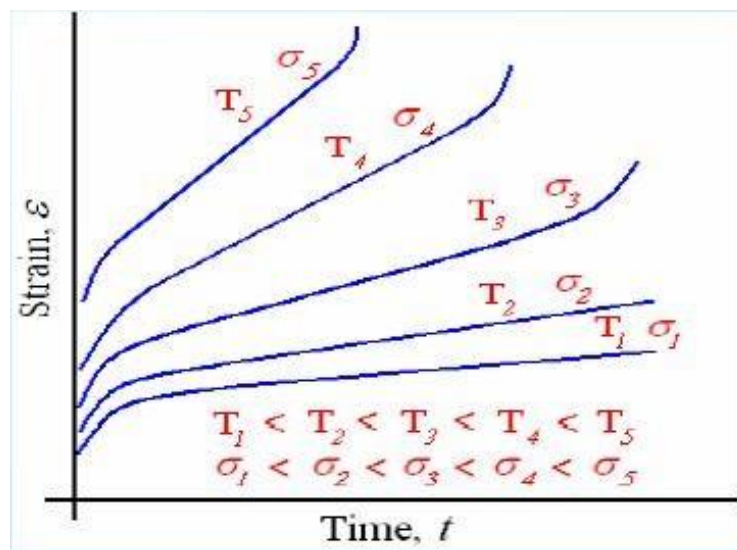

Dislocations and Strengthening Mechanisms

Basic Concept of dislocation

Dislocations can be *edge dislocations*, *screw dislocations* and exist in combination of the two. Their motion (slip) occurs by sequential bond breaking and bond reforming . The number of dislocations per unit volume is the *dislocation density*, in a plane they are measured per unit area.

Characteristics of Dislocations

There is strain around a dislocation which influences how they interact with other dislocations, impurities, etc. There is *compression* near the extra plane (higher atomic density) and *tension* following the dislocation line. Dislocations interact among themselves. When they are in the same plane, they repel if they have the same sign and annihilate if they have opposite signs (leaving behind a perfect crystal). In general, when dislocations are close and their strain fields add to a larger value, they repel, because being close increases the potential energy (it takes energy to strain a region of the material). The number of dislocations increases dramatically during plastic deformation. Dislocations spawn from existing dislocations, and from defects, grain boundaries and surface irregularities.

Plastic Deformation

Slip directions vary from crystal to crystal. When plastic deformation occurs in a grain, it will be constrained by its neighbors, which may be less favorably oriented. As a result, *polycrystalline metals are stronger than single crystals* (the exception is the perfect single crystal, as in whiskers.)

Mechanisms of Strengthening in Metals

General principles. Ability to deform plastically depends on ability of dislocations to move. Strengthening consists in hindering dislocation motion. We discuss the methods of grain-size reduction, solid-solution alloying and strain hardening. These are for single phase metals. We discuss others when treating alloys. Ordinarily, strengthening reduces ductility.

Strengthening by Grain Size Reduction

This is based on the fact that it is difficult for a dislocation to pass into another grain, especially if it is very misaligned. Atomic disorder at the boundary causes discontinuity in slip planes. For high-angle grain boundaries, stress at end of slip plane may trigger new dislocations in adjacent grains. Small angle grain boundaries are not effective in blocking dislocations.

The finer the grains, the larger the area of grain boundaries that impedes dislocation motion. Grain-size reduction usually improves toughness as well. Grain size can be controlled by the rate of solidification and by plastic deformation.

Solid-Solution Strengthening

Adding another element that goes into interstitial or substitutional positions in a solution increases strength. The impurity atoms cause lattice strain (Figs. 7.17 and 7.18) which can "anchor" dislocations. This occurs when the strain caused by the alloying element compensates that of the dislocation, thus achieving a state of low potential energy. It costs strain energy for the dislocation to move away from this state (which is like a potential well). The scarcity of energy at low temperatures is why slip is hindered. Pure metals are almost always softer than their alloys.

Strain Hardening

Phenomenon where ductile metals become stronger and harder when they are deformed plastically is called strain hardening or work hardening. Increasing temperature lowers the rate of strain hardening. Hence materials are strain hardened at low temperatures, thus also called cold working. During plastic deformation, dislocation density increases. And thus their interaction with each other resulting in increase in yield stress. Strain hardening (work hardening) is the reason for the elastic recovery. The reason for strain hardening is that the dislocation density increases with plastic deformation (cold work) due to multiplication. The average distance between dislocations then decreases and dislocations start blocking the motion of each one

Non-Destructive testing (NDT)

NDT is the method of detection and measurement of properties or condition of materials, structures, machines without damaging or destroying their operational capabilities. Examples of

NDT are: **magnetic dust method, penetrating liquid method, ultrasonic test and radiography**. All NDTs are used to detect various types of flaws on the surface of material or internal inclusions of impurities and these techniques are also very useful during preventive maintenance and repair. There are few techniques which do not require any special apparatus and are quite simple to handle and only a moderate skill being required. Some of the applications of NDTs are detecting: (i) surface cracks (ii) material composition (iii) internal inclusions (iv) internal voids and discontinuities and (v) condition of internal stresses.

Ultrasonic Test

High frequency ultrasonic (sound) waves are applied to the test piece by a Piezoelectric crystal. If the test piece is free from cracks, or flawless, then it reflects ultrasonic waves without distortion. If there are any flaws in the specimen, the time taken by the ultrasonic waves will be less as the reflection of these waves will be from flaw points and not from the bottom of the specimen. Cathode ray oscilloscope (CRO) is used to receive the sound signals, whose time base circuit is connected to it. Knowing the time interval between the transmission of the sound pulse and the reception of the echo signal, we can calculate the depth of the crack. This test is a very fast method of inspection and often used to test aerospace components and automobiles. This test is generally used to detect internal cracks like shrinkage cavities, hot tears, zones of corrosion and non-metallic inclusions.

Liquid-Penetration test

This test is employed for detection of small defects which are very small to detect with the naked eye. This test is used to detect surface cracks or flaws in non-ferrous metals. This test employs a visible colour contrast dye penetrant technique for the detection of open surface flaws in metallic and non-metallic objects. The penetrants are applied by spraying over the surface of material to be inspected. The excess penetrant is then washed or cleaned. Absorbent powder is then applied to absorb the penetrants in the cracks, voids which reveals the flaws. This test reveals flaws such as shrinkage cracks, porosity, fatigue cracks, grinding cracks, forging cracks, seams, heat treatment cracks and leaks etc., on castings, weldings, machined parts, cutting tools, pipes and tubes. If the fluorescent penetrant is used, the developed surface must be examined under ultra violet light to see the presence of defects. This technique is used for non-porous and non-absorbent materials. Care may be taken to clean the surface so that it is free from dust, scale, etc.

to have better results. Penetrants are highly toxic and flammable and hence proper precautions should be taken both during use and of storage of penetrants.

Microstructural Exam

Microstructure is defined as the structure of a prepared surface or thin foil of material as revealed by a microscope above 25× magnification. The microstructure of a material can strongly influence physical properties such as strength, toughness, ductility, hardness, corrosion resistance, high/low temperature behavior, wear resistance, and so on, which in turn govern the application of these materials in industrial practice.

a) Sectioning and cutting

The areas of interest forming the metallography specimens need to be sectioned for ease of handling. Depending on the type of material, the sectioning operation can be done by using abrasive cutter (for metal and metallic composite), diamond wafer cutter (ceramics, electronics and minerals) or thin sectioning with a microtome (plastics). In order not to damage the specimen, proper cutting requires the correct selection of abrasive cutting wheel, proper cutting speed & cutting load and the use of coolant.

b) Mounting

The mounting operation accomplishes three important functions:

1. To protect the specimen edge and maintain the integrity of materials surface features.
2. Fill voids in porous materials.
3. Improves handling of irregular shaped samples.

Samples for microstructure evaluation are typically encapsulated in a plastic mount for handling during sample preparation. Large sample or samples for macrostructure evaluation can be prepared without mounting.

The metallography specimen mounting is done by encapsulating the specimen into:

1. A compression/hot mounting compound (thermosets – e.g. phenolics, epoxies or thermoplastics – e.g. acrylics)

2. A castable resin/cold mounting (e.g. acrylics resins, epoxy resins and polyester resins)

c) Grinding

Grinding is required to ensure the surface is flat & parallel and to reduce the damage created during sectioning. Grinding is accomplished by decreasing the abrasive grit size sequentially to obtain the required fine surface finish prior to polishing. It is important to note that the final appearance of the prepared surface is dependent on the machine parameters such as grinding/polishing pressure, relative velocity distribution and the direction of grinding/polishing.

d) Polishing

For microstructure examination a mirror/reflective finish is needed whereas a finely ground finish is adequate for macrostructure evaluation. Polishing can be divided into two main steps:

1. Rough polishing

The purpose is to remove the damage produced during grinding. Proper polishing will maintain the specimen flatness and retain all inclusions or secondary phases by eliminating the previous damage and maintaining the specimen integrity.

2. Fine polishing

The purpose is to remove only surface damage.

e) Etching

Etchants are specially formulated for the specific material and evaluation objectives. Etching alters the microstructural features based on composition; stress or crystal structure and it will develop the surface topology, which can be visible in the microscope. Typically, chemical etching involve immersing the polished surface in the prepared chemical solution for a specified time (usually seconds) followed by rinsing the etched specimen under running tap water and drying.

f) Microscopic Analysis

For microscopic analysis, a reflective surface is required. The analysis can be done by using a metallurgy microscope.

Grain size determination

The grain size is often determined when the properties of a polycrystalline material are under consideration. In this regard, there exist a number of techniques by which size is specified in terms of average grain volume, diameter, or area. Grain size may be estimated by using an intercept method, described as follows. Straight lines all the same length are drawn through several photomicrographs that show the grain structure. The grains intersected by each line segment are counted; the line length is then divided by an average of the number of grains intersected, taken over all the line segments. The average grain diameter is found by dividing this result by the linear magnification of the photomicrographs.

Grain size is measured with a microscope by counting the number of grains within a given area, by determining the number of grains that intersect a given length of random line, or by comparison with standard charts. The average grain diameter D can be determined from measurements along random lines by the equation

$$D = \frac{L}{N}$$

where L is the length of the line and N is the number of intercepts which the grain boundary makes with the line. This can be related to the ratio of the grain-boundary surface area S to the volume of the grains, V , by the equation

$$\frac{S}{V} = \frac{2N}{L} = \frac{4I}{A}$$

where I is the total length of grain boundary on a random plane of polish and A is the total area of the grains on a random plane of polish. A very common method of measuring grain size in the United States is to compare the grains at a fixed magnification with the American Society for Testing and Materials (ASTM) grain-size charts. The ASTM grain-size number n is related to N ,

the number of grains per square inch at a magnification of 100X by the relationship

$$N^* = 2^{n-1}$$

Table shown compares the ASTM grain-size numbers with several other useful measures of grain size.

ASTM #	Grains/in ² @ 100X	Grains/mm ²	Grains/mm ³	Ave. Grain Dia. (mm)
-3	0.06	1	0.7	1.00
-2	0.12	2	2	0.75
-1	0.25	4	5.6	0.50
0	0.5	8	16	0.35
1	1	16	45	0.25
2	2	32	128	0.18
3	4	64	360	0.125
4	8	128	1020	0.091
5	16	256	2990	0.062
6	32	512	8200	0.044
7	64	1024	23000	0.032
8	128	2048	65000	0.022
9	256	4096	185000	0.016
10	512	8200	520000	0.011
11	1024	16400	1200000	0.008
12	2048	32800	1500000	0.00096

MODULE – III

Phase Diagrams

Equilibrium Phase Diagrams

Give the relationship of composition of a solution as a function of temperatures and the quantities of phases in equilibrium. These diagrams do not indicate the dynamics when one phase transforms into another. Sometimes diagrams are given with pressure as one of the variables. In the phase diagrams we will discuss, pressure is assumed to be constant at one atmosphere.

Binary Isomorphous Systems

This very simple case is one complete liquid and solid solubility, an *isomorphous* system. The example is the Cu-Ni alloy of Fig. 9.2a. The complete solubility occurs because both Cu and Ni have the same crystal structure (FCC), near the same radii, electronegativity and valence. The *liquidus line* separates the liquid phase from solid or solid + liquid phases. That is, the solution is liquid above the liquidus line. The *solidus line* is that below which the solution is completely solid (does not contain a liquid phase.)

Interpretation of phase diagrams

Concentrations: Tie-line method

- a) locate composition and temperature in diagram
- b) In two phase region draw tie line or isotherm
- c) note intersection with phase boundaries. Read compositions.

Fractions: lever rule

- a) construct tie line (isotherm)
- b) obtain ratios of line segments lengths.

Development of microstructure in isomorphous alloys

a) Equilibrium cooling

Solidification in the solid + liquid phase occurs gradually upon cooling from the liquidus line. The composition of the solid and the liquid change gradually during cooling (as can be determined by the tie-line method.) Nuclei of the solid phase form and they grow to consume all the liquid at the solidus line.

b) Non-equilibrium cooling

Solidification in the solid + liquid phase also occurs gradually. The composition of the liquid phase evolves by diffusion, following the equilibrium values that can be derived from the tie-line method. However, diffusion in the solid state is very slow. Hence, the new layers that solidify on top of the grains have the equilibrium composition at that temperature but once they are solid their composition does not change. This leads to the formation of layered (cored) grains (Fig. 9.14) and to the invalidity of the tie-line method to determine the composition of the solid phase (it still works for the liquid phase, where diffusion is fast.)

Binary Eutectic Systems

Interpretation: Obtain phases present, concentration of phases and their fraction (%). *Solvus line*: limit of solubility **Eutectic** or invariant point. Liquid and two solid phases exist in equilibrium at the *eutectic composition* and the *eutectic temperature*. The melting point of the eutectic alloy is

lower than that of the components (eutectic = easy to melt in Greek). • At most two phases can be in equilibrium within a phase field. • Single-phase regions are separated by 2-phase regions.

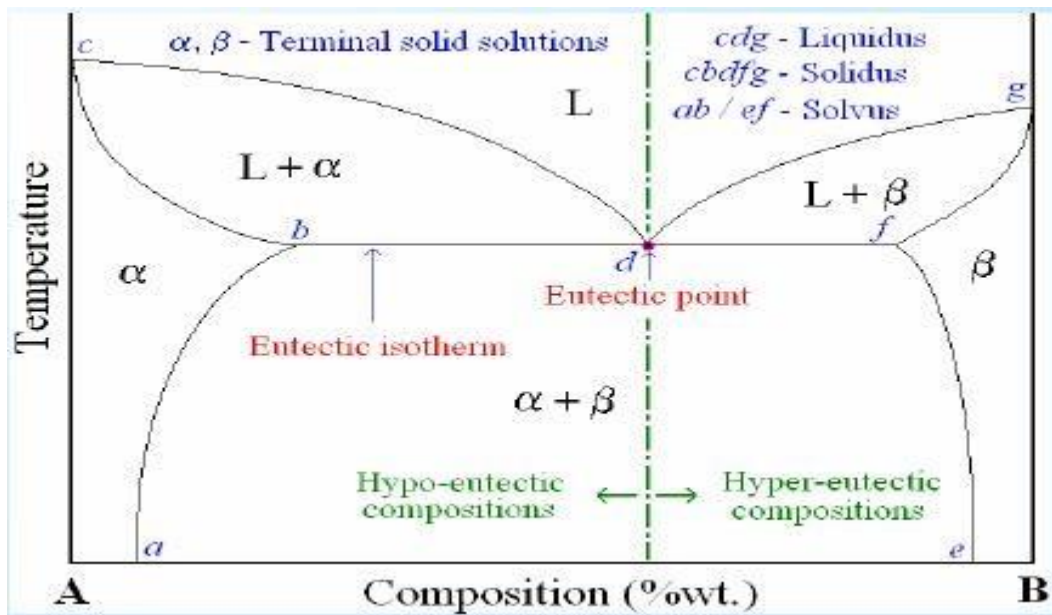
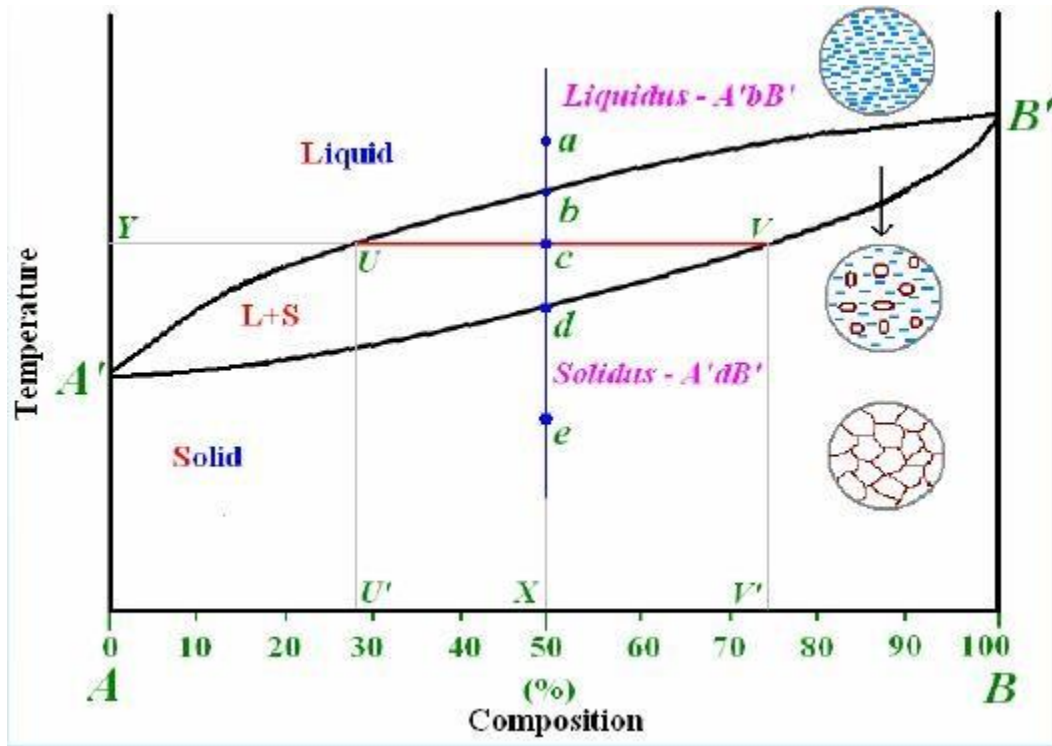

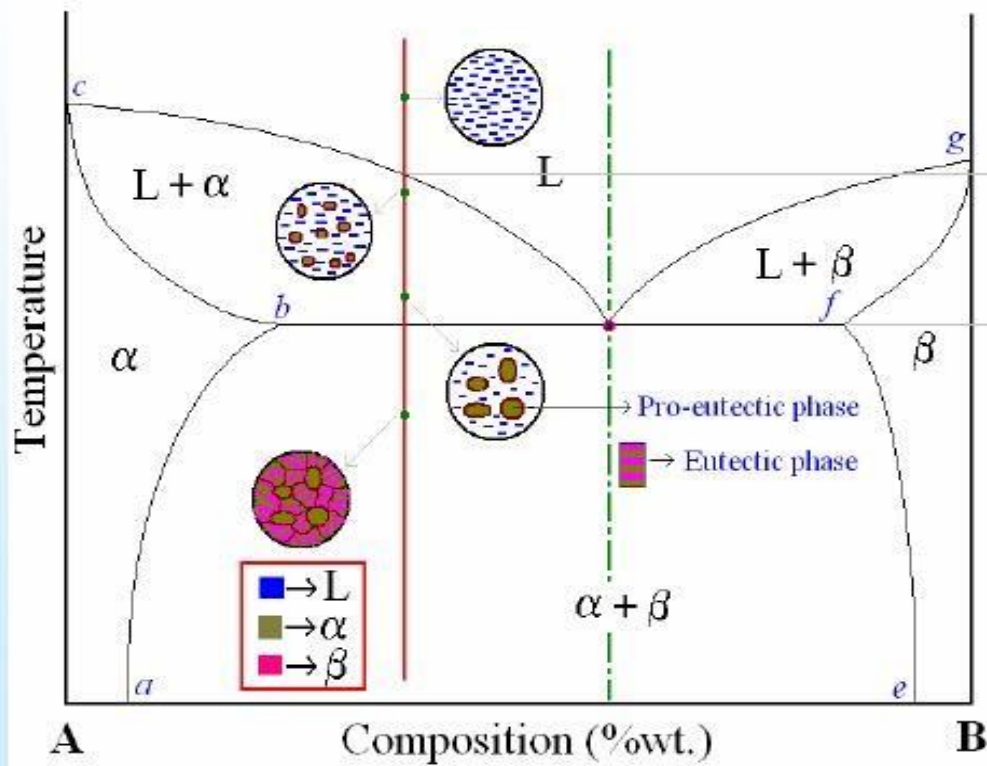
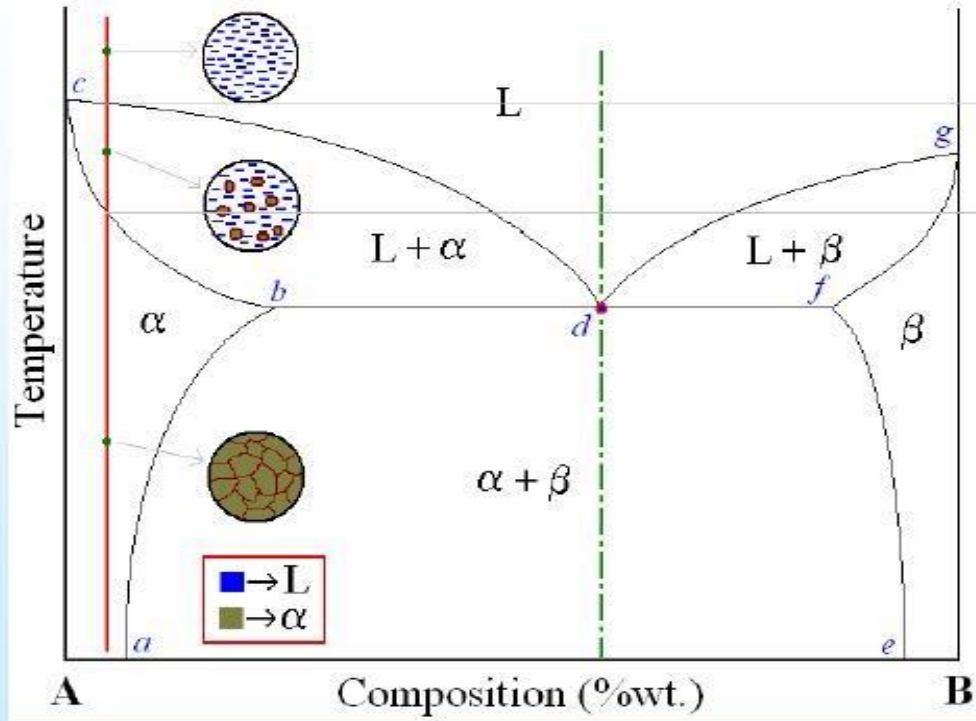

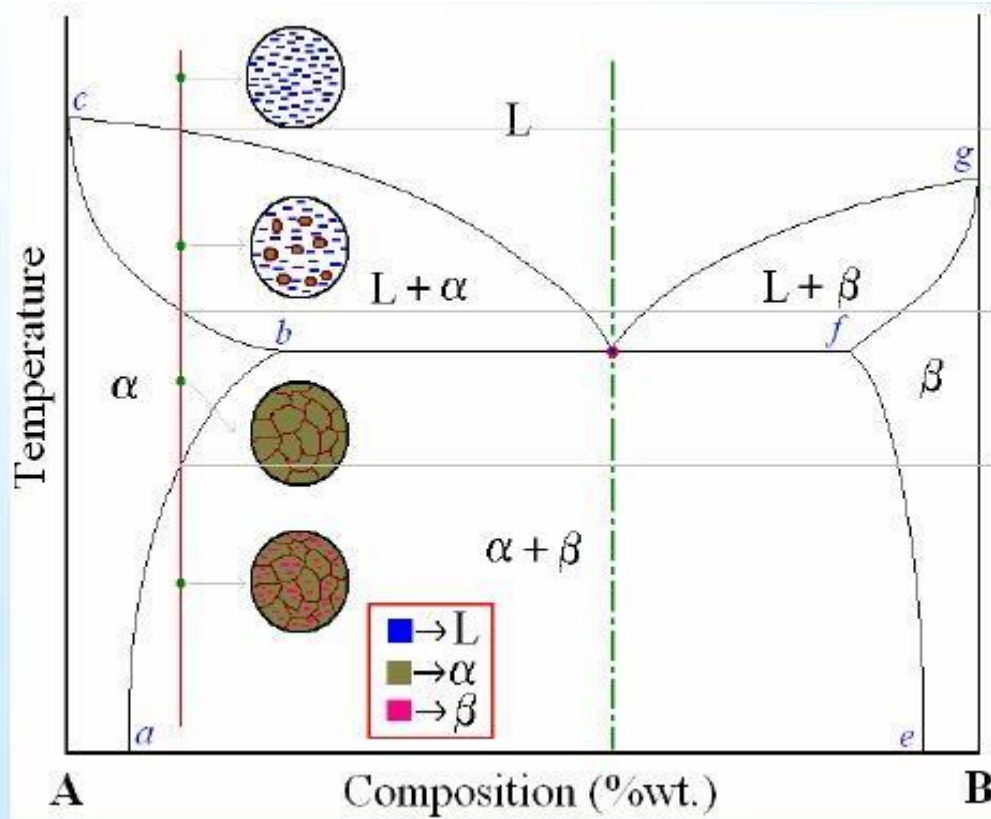
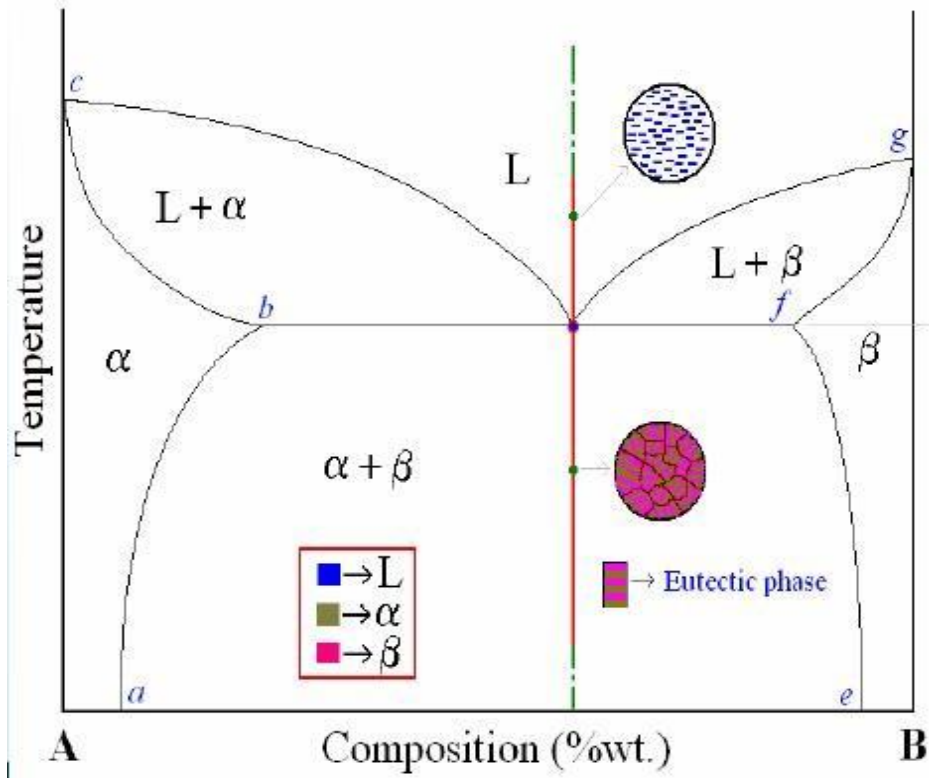

Development of microstructure in eutectic alloys

Case of lead-tin alloys, A layered, eutectic structure develops when cooling below the eutectic temperature. Alloys which are to the left of the eutectic concentration (*hipoeutectic*) or to the right (*hypereutectic*) form a *proeutectic* phase before reaching the eutectic temperature, while in the solid + liquid region. The eutectic structure then adds when the remaining liquid is solidified when cooling further. The eutectic microstructure is lamellar (layered) due to the reduced diffusion distances in the solid state. To obtain the concentration of the eutectic microstructure in the final solid solution, one draws a vertical line at the eutectic concentration and applies the lever rule treating the eutectic as a separate phase.

Eutectoid and Peritectic Reactions

The *eutectoid* (eutectic-like) reaction is similar to the eutectic reaction but occurs from one solid phase to two *new* solid phases. It also shows as V on top of a horizontal line in the phase diagram. There are associated eutectoid temperature (or temperature), eutectoid phase, eutectoid and proeutectoid microstructures.

The *peritectic* reaction also involves three solid in equilibrium, the transition is from a solid + liquid phase to a *different* solid phase when cooling. The inverse reaction occurs when heating.

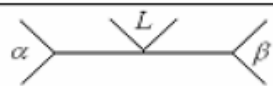
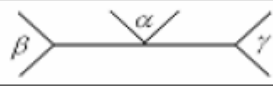
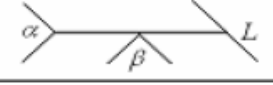
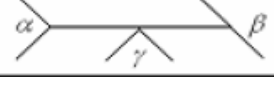
Reaction	Symbolic equation	Schematic presentation	Example
Eutectic	$L \rightarrow \alpha + \beta$		Fe-C, 4.27% C, 1147 C
Eutectoid	$\alpha \rightarrow \beta + \gamma$		Fe-C, 0.80% C, 723 C
Peritectic	$L + \alpha \rightarrow \beta$		Fe-C, 0.16% C, 1495 C
Peritectoid	$\alpha + \beta \rightarrow \gamma$		

Particle strengthening by precipitation

The strength and hardness of some metal and alloys may be enhanced by the formation of extremely small uniformly dispersed particles of a second phase within the original phase matrix; this must be accomplished by phase transformations that are induced by appropriate heat

treatments. The process is called **precipitation hardening** because the small particles of the new phase are termed “precipitates”. Precipitation hardening and the treating of steel to form tempered martensite are totally different phenomena, even though the heat treatment procedures are similar.

Precipitation reactions

A precipitation reaction is a reaction in which soluble ions in separate solutions are mixed together to form an insoluble compound that settles out of solution as a solid. That insoluble compound is called a precipitate

Kinetics of nucleation and growth

From a micro structural standpoint, the first process to accompany a phase transformation is **nucleation**- the formation of very small particles or nuclei, of the new phase which are capable of growing. The second stage is **growth**, in which the nuclei increase in size; during this process, some volume of the parent phase disappears. The transformation reaches completion if growth of these new phase particles is allowed to proceed until the equilibrium fraction is attained.

As would be expected, the time dependence of the transformations rate (which is often termed the **kinetics** of a transformation) is an important consideration in the heat treatment of materials. With many investigations, the fraction of reaction that has occurred is measured as a function of time, while the temperature is maintained constant. Transformation progress is usually ascertained by either microscopic examination or measurement of some physical property. Data are plotted as the fraction of transformed material versus the logarithm of time; an S-shaped curve, represents the typical kinetic behavior for most solid state reactions.

Solid Solutions

A solid solution may be formed when impurity atoms are added to a solid, in which case the original crystal structure is retained and no new phases are formed.

- **Substitutional solid solutions:** impurity atoms substitute for host atoms, and appreciable solubility is possible only when atomic diameters and electronegativities for both atom types are similar, when both elements have the same crystal structure, and when the impurity atoms have a valence that is the same as or less than the host material.

- **Interstitial solid solutions:** These form for relatively small impurity atoms that occupy interstitial sites among the host atoms

The Iron–Carbon Diagram

The Iron–Iron Carbide (Fe–Fe₃C) Phase Diagram

This is one of the most important alloys for structural applications. The diagram Fe–C is simplified at low carbon concentrations by assuming it is the Fe–Fe₃C diagram. Concentrations are usually given in weight percent. The possible phases are:

- α -ferrite (BCC) Fe-C solution
- γ -austenite (FCC) Fe-C solution
- δ -ferrite (BCC) Fe-C solution
- liquid Fe-C solution
- Fe₃C (iron carbide) or cementite. An intermetallic compound.

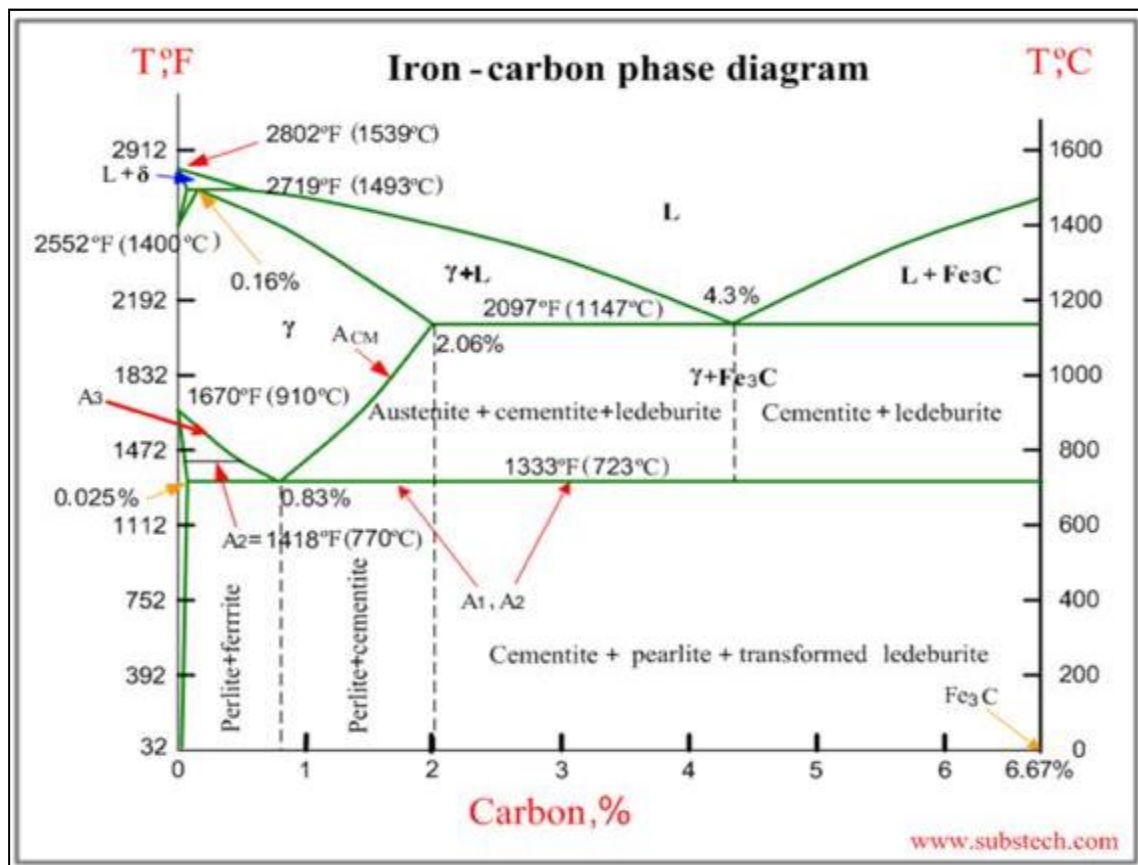

The maximum solubility of C in α - ferrite is 0.022 wt%. δ -ferrite is only stable at high temperatures. It is not important in practice. Austenite has a maximum C concentration of 2.14 wt %. It is not stable below the eutectic temperature (727 C) unless cooled rapidly (Chapter 10). Cementite is in reality metastable, decomposing into α -Fe and C when heated for several years between 650 and 770 C.

- ← **δ -ferrite:** – It is solid solution of carbon in δ -iron. Maximum concentration of carbon in δ -ferrite is 0.09% at 2719 °F (1493°C) which is the temperature of the peritectic transformation. The crystal structure of δ -ferrite is BCC (cubic body centered).
- ← **Austenite:** – Austenite is interstitial solid solution of carbon in γ -iron. Austenite has FCC (cubic face centered) crystal structure, permitting high solubility of carbon i.e. up to 2.06% at 2097 °F (1147 °C). Austenite does not exist below 1333 °F (723°C) and maximum carbon concentration at this temperature is 0.83%.
- ← **α -ferrite:** – It is solid solution of carbon in α -iron. α -ferrite has BCC crystal structure and low solubility of carbon – up to 0.025% at 1333 °F (723°C). α -ferrite exists at room temperature.
- ← **Cementite** – Cementite is also known as iron carbide, is an intermetallic compound of iron and carbon, having fixed composition Fe_3C . Cementite is a hard and brittle substance, influencing the properties of steels and cast irons.

Critical temperatures

- ← **Upper critical temperature (point) A_3** is the temperature, below which ferrite starts to form as a result of ejection from austenite in the hypo-eutectoid alloys.
- ← **Upper critical temperature (point) A_{CM}** is the temperature, below which cementite starts to form as a result of ejection from austenite in the hyper-eutectoid alloys.
- ← **Lower critical temperature (point) A_1** is the temperature of the austenite-to-Pearlite eutectoid transformation. Below this temperature austenite does not exist.
- ← **Magnetic transformation temperature A_2** is the temperature below which α -ferrite is ferromagnetic.

Phase compositions of the iron-carbon alloys at room temperature

- ← **Hypoeutectoid steels** (carbon content from 0 to 0.83%) consist of primary (proeutectoid) ferrite (according to the curve A₃) and Pearlite.
- ← **Eutectoid steel** (carbon content 0.83%) entirely consists of Pearlite.
- ← **Hypereutectoid steels** (carbon content from 0.83 to 2.06%) consist of primary (proeutectoid) cementite (according to the curve A_{CM}) and Pearlite.
- ← **Cast irons** (carbon content from 2.06% to 4.3%) consist of cementite ejected from austenite according to the curve A_{CM} , Pearlite and transformed ledeburite (ledeburite in which austenite transformed to pearlite).

When the liquid of eutectic composition is cooled, at or below eutectic temperature this liquid transforms simultaneously into two solid phases (two terminal solid solutions, represented by α and β). This transformation is known as eutectic reaction and is written symbolically as:

Liquid (L) \leftrightarrow solid solution-1 (α) + solid solution-2 (β)

In the solid state analog of a eutectic reaction, called a eutectoid reaction, one solid phase having eutectoid composition transforms into two different solid phases. Another set of invariant reactions that occur often in binary systems are - peritectic reaction where a solid phase reacts with a liquid phase to produce a new solid phase.

For their role in mechanical properties of the alloy, it is important to note that: ***Ferrite is soft and ductile Cementite is hard and brittle.*** Thus, combining these two phases in solution an alloy can be obtained with intermediate properties. (Mechanical properties also depend on the microstructure, that is, how ferrite and cementite are mixed.)

Development of Microstructures in Iron—Carbon Alloys

The eutectoid composition of austenite is 0.8 wt %. When it cools *slowly* it forms *perlite*, a lamellar or layered structure of two phases: α -ferrite and cementite (Fe₃C). Hypoeutectoid alloys contain *proeutectoid ferrite* plus the eutectoid pearlite. Hypereutectoid alloys contain *proeutectoid cementite* plus pearlite. Since reactions below the eutectoid temperature are in the solid phase, the equilibrium is not achieved by usual cooling from austenite.

The Influence of Other Alloying Elements

Alloying strengthens metals by hindering the motion of dislocations. Thus, the strength of Fe–C alloys increase with C content and also with the addition of other elements.

Time-temperature transformation (TTT) diagrams measure the rate of transformation at a constant temperature. In other words a sample is austenitised and then cooled rapidly to a lower temperature and held at that temperature whilst the rate of transformation is measured, for example by dilatometry. Obviously a large number of experiments is required to build up a complete TTT diagram.

- An increase in carbon content shifts the TTT curve to the right (this corresponds to an increase in hardenability as it increases the ease of forming martensite - i.e. the cooling rate required to attain martensite is less severe).
- An increase in carbon content decreases the martensite start temperature.
- An increase in Mo content shifts the TTT curve to the right and also separates the ferrite + pearlite region from the bainite region making the attainment of a bainitic structure more controllable.

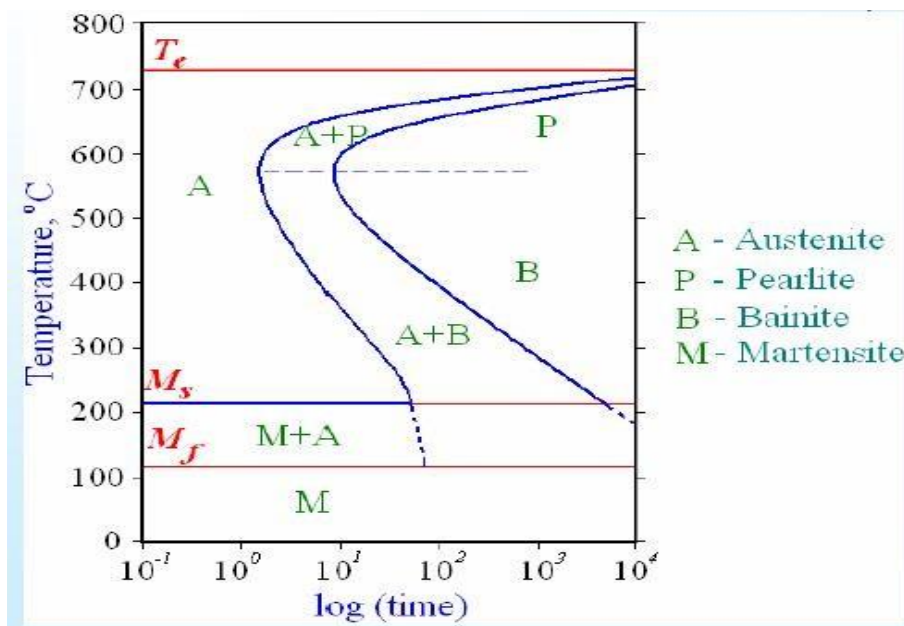

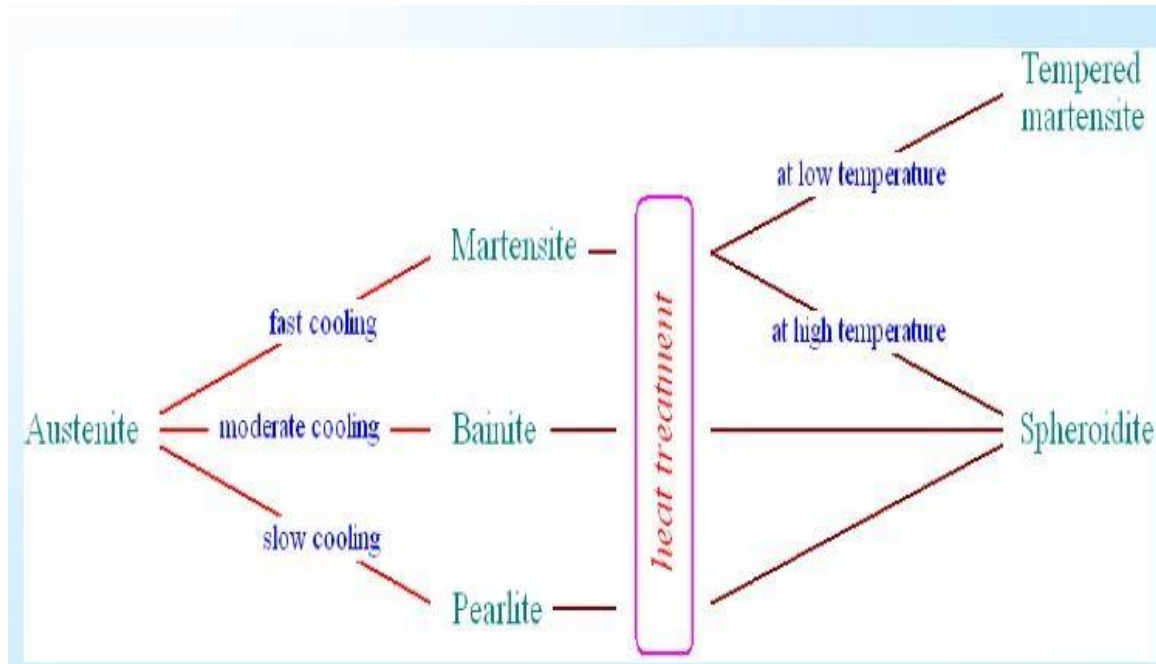

Microstructure and Property Changes in Fe-C Alloys

Isothermal Transformation Diagrams

We use as an example the cooling of an eutectoid alloy (0.8 % C) from the austenite (γ - phase) to pearlite, that contains ferrite (α) plus cementite (Fe_3C or iron carbide). When cooling proceeds below the eutectoid temperature ($727\text{ }^\circ\text{C}$) nucleation of pearlite starts. The S-shaped curves (fraction of pearlite vs. log. time, fig. 10.3) are displaced to longer times at higher temperatures showing that the transformation is dominated by nucleation (the nucleation period is longer at higher temperatures) and not by diffusion (which occurs faster at higher temperatures).

The family of S-shaped curves at different temperatures can be used to construct the TTT (Time-Temperature-Transformation) diagrams. For these diagrams to apply, one needs to cool the material quickly to a given temperature T_0 before the transformation occurs, and keep it at that temperature over time. The horizontal line that indicates constant temperature T_0 intercepts the TTT curves on the left (beginning of the transformation) and the right (end of the transformation); thus one can read from the diagrams when the transformation occurs. The formation of pearlite indicates that the transformation occurs sooner at low temperatures, which is an indication that it is controlled by the rate of nucleation. At low temperatures, nucleation occurs fast and grain growth is reduced (since it occurs by diffusion, which is hindered at low

temperatures). This reduced grain growth leads to fine-grained microstructure (**fine pearlite**). At higher temperatures, diffusion allows for larger grain growth, thus leading to **coarse pearlite**.

At lower temperatures nucleation starts to become slower, and a new phase is formed, **bainite**. Since diffusion is low at low temperatures, this phase has a very fine (microscopic) microstructure.

Spheroidite is a coarse phase that forms at temperatures close to the eutectoid temperature. The relatively high temperatures caused a slow nucleation but enhances the growth of the nuclei leading to large grains.

A very important structure is **martensite**, which forms when cooling austenite very fast (**quenching**) to below a maximum temperature that is required for the transformation. It forms nearly instantaneously when the required low temperature is reached; since no thermal activation is needed, this is called an *athermal transformation*. Martensite is a different phase, a body-centered tetragonal (BCT) structure with interstitial C atoms. Martensite is *metastable* and decomposes into ferrite and pearlite but this is extremely slow (and not noticeable) at room temperature.

In the examples, we used an eutectoid composition. For hypo- and hypereutectoid alloys, the analysis is the same, but the proeutectoid phase that forms before cooling through the eutectoid temperature is also part of the final microstructure.

MODULE –IV

Various types of carbon steel

Carbon steel is steel in which the main interstitial alloying constituent is carbon in the range of 0.12–2.0%. The American Iron and Steel Institute (AISI) defines carbon steel as the following: "Steel is considered to be carbon steel when no minimum content is specified or required for chromium, cobalt, molybdenum, nickel, niobium, titanium, tungsten, vanadium or zirconium, or any other element to be added to obtain a desired alloying effect; when the specified minimum for copper does not exceed 0.40 percent; or when the maximum content specified for any of the following elements does not exceed the percentages noted: manganese 1.65, silicon 0.60, copper 0.60.

Types:

Carbon steel is broken down into four classes based on carbon content:

Mild and low-carbon steel

Mild steel also known as plain-carbon steel, is the most common form of steel because its price is relatively low while it provides material properties that are acceptable for many applications, more so than iron. Low-carbon steel contains approximately 0.05–0.320 % carbon making it malleable and ductile. Mild steel has a relatively low tensile strength, but it is cheap and malleable; surface hardness can be increased through carburizing.

It is often used when large quantities of steel are needed, for example as structural steel. The density of mild steel is approximately 7.85 g/cm^3 (7850 kg/m^3 or 0.284 lb/in^3) and the Young's modulus is 210 GPa (30,000,000 psi).

Low-carbon steels suffer from yield-point run out where the material has two yield points. The first yield point (or upper yield point) is higher than the second and the yield drops dramatically after the upper yield point. If low-carbon steel is only stressed to some point between the upper and lower yield point then the surface may develop loder bands. Low-carbon steels contain less carbon than other steels and are easier to cold-form, making them easier to handle.

Higher carbon steels

Carbon steels which can successfully undergo heat-treatment have carbon content in the range of 0.30–1.70% by weight. Trace impurities of various other elements can have a significant effect on the quality of the resulting steel. Trace amounts of sulfur in particular make the steel red-short, that is, brittle and crumbly at working temperatures. Low-alloy carbon steel, such as A36 grade, contains about 0.05% sulfur and melts around 1,426–1,53°C (2,599–2,800°F). Manganese is often added to improve the harden ability of low-carbon steels. These additions turn the material into low-alloy steel by some definitions, but AISI's definition of carbon steel allows up to 1.65% manganese by weight.

Low carbon steel

Less than 0.3% carbon content

Medium carbon steel

Approximately 0.30–0.59% carbon content. Balances ductility and strength and has good wear resistance; used for large parts, forging and automotive components.

High-carbon steel

Approximately 0.6–0.99% carbon content. Very strong, used for springs and high-strength wires.

Ultra-high-carbon steel

Approximately 1.0–2.0% carbon content. Steels that can be tempered to great hardness. Used for special purposes like (non-industrial-purpose) knives, axles or punches. Most steels with more than 1.2% carbon content are made using powder metallurgy. Note that steel with carbon content above 2.14% is considered cast iron.

Alloy steel

Alloy steel is steel that is alloyed with a variety of elements in total amounts between 1.0% and 50% by weight to improve its mechanical properties. Alloy steels are broken down into two groups: low-alloy steels and high-alloy steels. The difference between the two is somewhat

arbitrary: Smith and Has hemi define the difference at 4.0%, while Degarmo, et al., define it at 8.0%. Most commonly, the phrase "alloy steel" refers to low-alloy steels.

Types:

According to the World Steel Association, there are over 3,500 different grades of steel, encompassing unique physical, chemical and environmental properties.

In essence, steel is composed of iron and carbon, although it is the amount of carbon, as well as the level of impurities and additional alloying elements that determines the properties of each steel grade.

The carbon content in steel can range from 0.1-1.5%, but the most widely used grades of steel contain only 0.1-0.25% carbon. Elements such as manganese, phosphorus and sulphur are found in all grades of steel, but, whereas manganese provides beneficial effects, phosphorus and sulphur are deleterious to steel's strength and durability.

Different types of steel are produced according to the properties required for their application, and various grading systems are used to distinguish steels based on these properties. According to the American Iron and Steel Institute (AISI), steels can be broadly categorized into four groups based on their chemical compositions:

1. Carbon Steels
2. Alloy Steels
3. Stainless Steels
4. Tool Steels

Carbon Steels:

Carbon steels contain trace amounts of alloying elements and account for 90% of total steel production. Carbon steels can be further categorized into three groups depending on their carbon content:

- Low Carbon Steels/Mild Steels contain up to 0.3% carbon
- Medium Carbon Steels contain 0.3 – 0.6% carbon

- High Carbon Steels contain more than 0.6% carbon

1) Alloy Steels:

Alloy steels contain alloying elements (e.g. manganese, silicon, nickel, titanium, copper, chromium and aluminum) in varying proportions in order to manipulate the steel's properties, such as its hardenability, corrosion resistance, strength, formability, weldability or ductility. Applications for alloys steel include pipelines, auto parts, transformers, power generators and electric motors.

2) Stainless Steels:

Stainless steels generally contain between 10-20% chromium as the main alloying element and are valued for high corrosion resistance. With over 11% chromium, steel is about 200 times more resistant to corrosion than mild steel. These steels can be divided into three groups based on their crystalline structure:

- **Austenitic:** Austenitic steels are non-magnetic and non heat-treatable, and generally contain 18% chromium, 8% nickel and less than 0.8% carbon. Austenitic steels form the largest portion of the global stainless steel market and are often used in food processing equipment, kitchen utensils and piping.
- **Ferritic:** Ferritic steels contain trace amounts of nickel, 12-17% chromium, less than 0.1% carbon, along with other alloying elements, such as molybdenum, aluminum or titanium. These magnetic steels cannot be hardened with heat treatment, but can be strengthened by cold works.
- **Martensitic:** Martensitic steels contain 11-17% chromium, less than 0.4% nickel and up to 1.2% carbon. These magnetic and heat-treatable steels are used in knives, cutting tools, as well as dental and surgical equipment.

3) Tool Steels:

Tool steels contain tungsten, molybdenum, cobalt and vanadium in varying quantities to increase heat resistance and durability, making them ideal for cutting and drilling equipment.

Steel products can also be divided by their shapes and related applications:

- Long/Tubular Products include bars and rods, rails, wires, angles, pipes, and shapes and sections. These products are commonly used in the automotive and construction sectors.
- Flat Products include plates, sheets, coils and strips. These materials are mainly used in automotive parts, appliances, packaging, shipbuilding, and construction.
- Other Products include valves, fittings, and flanges and are mainly used as piping materials.

Cast iron

Cast iron is iron or a ferrous alloy which has been heated until it liquefies, and is then poured into a mould to solidify. It is usually made from pig iron. The alloy constituents affect its colour when fractured: white cast iron has carbide impurities which allow cracks to pass straight through. Grey cast iron has graphite flakes which deflect a passing crack and initiate countless new cracks as the material breaks.

Carbon (C) and silicon (Si) are the main alloying elements, with the amount ranging from 2.1–4 wt% and 1–3 wt%, respectively. Iron alloys with less carbon content are known as steel. While this technically makes these base alloys ternary Fe–C–Si alloys, the principle of cast iron solidification is understood from the binary iron–carbon phase diagram. Since the compositions of most cast irons are around the eutectic point of the iron–carbon system, the melting temperatures closely correlate, usually ranging from 1,150 to 1,200 °C (2,100 to 2,190 °F), which is about 300 °C (572 °F) lower than the melting point of pure iron.

Cast iron's properties are changed by adding various alloying elements, or alloyants. Next to carbon, silicon is the most important alloying because it forces carbon out of solution. Instead the carbon forms graphite which results in a softer iron, reduces shrinkage, lowers strength, and decreases density. Sulfur, when present, forms iron sulfide, which prevents the formation of graphite and increases hardness. The problem with sulfur is that it makes molten cast iron sluggish, which causes short run defects. To counter the effects of sulfur, manganese is added because the two form into manganese sulfide instead of iron sulfide. The manganese sulfide is lighter than the melt so it tends to float out of the melt and into the slag. The amount of manganese required to neutralize sulfur is $1.7 \times \text{sulfur content} + 0.3\%$. If more than this amount

of manganese is added, then manganese carbide forms, which increases hardness and chilling, except in grey iron, where up to 1% of manganese increases strength and density.

Nickel is one of the most common alloying elements because it refines the pearlite and graphite structure, improves toughness, and evens out hardness differences between section thicknesses. Chromium is added in small amounts to the ladle to reduce free graphite, produce chill, and because it is a powerful carbide stabilizer; nickel is often added in conjunction. A small amount of tin can be added as a substitute for 0.5% chromium. Copper is added in the ladle or in the furnace, on the order of 0.5–2.5%, to decrease chill, refine graphite, and increase fluidity. Molybdenum is added on the order of 0.3–1% to increase chill and refine the graphite and pearlite structure; it is often added in conjunction with nickel, copper, and chromium to form high strength irons. Titanium is added as a degasser and deoxidizer, but it also increases fluidity. 0.15–0.5% vanadium is added to cast iron to stabilize cementite, increase hardness, and increase resistance to wear and heat. 0.1–0.3% zirconium helps to form graphite, deoxidize, and increase fluidity.

In malleable iron melts, bismuth is added, on the scale of 0.002–0.01%, to increase how much silicon can be added. In white iron, boron is added to aid in the production of malleable iron; it also reduces the coarsening effect of bismuth.

Grey cast iron

Grey cast iron is characterised by its graphitic microstructure, which causes fractures of the material to have a grey appearance. It is the most commonly used cast iron and the most widely used cast material based on weight. Most cast irons have a chemical composition of 2.5–4.0% carbon, 1–3% silicon, and the remainder is iron. Grey cast iron has less tensile strength and shock resistance than steel, but its compressive strength is comparable to low and medium carbon steel.

White cast iron

It is the cast iron that displays white fractured surface due to the presence of cementite. With a lower silicon content (graphitizing agent) and faster cooling rate, the carbon in white cast iron precipitates out of the melt as the metastable phase cementite, Fe_3C , rather than graphite. The

cementite which precipitates from the melt forms as relatively large particles, usually in a eutectic mixture, where the other phase is austenite (which on cooling might transform to martensite). These eutectic carbides are much too large to provide precipitation hardening (as in some steels, where cementite precipitates might inhibit plastic deformation by impeding the movement of dislocations through the ferrite matrix). Rather, they increase the bulk hardness of the cast iron simply by virtue of their own very high hardness and their substantial volume fraction, such that the bulk hardness can be approximated by a rule of mixtures. In any case, they offer hardness at the expense of toughness. Since carbide makes up a large fraction of the material, white cast iron could reasonably be classified as a cermet. White iron is too brittle for use in many structural components, but with good hardness and abrasion resistance and relatively low cost, it finds use in such applications as the wear surfaces (impeller and volute) of slurry pumps, shell liners and lifter bars in ball mills and autogenous grinding mills, balls and rings in coal pulverisers, and the teeth of a backhoe's digging bucket (although cast medium-carbon martensitic steel is more common for this application).

It is difficult to cool thick castings fast enough to solidify the melt as white cast iron all the way through. However, rapid cooling can be used to solidify a shell of white cast iron, after which the remainder cools more slowly to form a core of grey cast iron. The resulting casting, called a chilled casting, has the benefits of a hard surface and a somewhat tougher interior.

High-chromium white iron alloys allow massive castings (for example, a 10-tonne impeller) to be sand cast, i.e., a high cooling rate is not required, as well as providing impressive abrasion resistance. These high-chromium alloys attribute their superior hardness to the presence of chromium carbides. The main form of these carbides are the eutectic or primary M_7C_3 carbides, where "M" represents iron or chromium and can vary depending on the alloy's composition. The eutectic carbides form as bundles of hollow hexagonal rods and grow perpendicular to the hexagonal basal plane. The hardness of these carbides are within the range of 1500-1800HV

Malleable cast iron

Malleable iron starts as a white iron casting that is then heat treated at about 900 °C (1,650 °F). Graphite separates out much more slowly in this case, so that surface tension has time to form it into spheroidal particles rather than flakes. Due to their lower aspect ratio, spheroids are











relatively short and far from one another, and have a lower cross section vis-a-vis a propagating crack or phonon. They also have blunt boundaries, as opposed to flakes, which alleviates the stress concentration problems faced by grey cast iron. In general, the properties of malleable cast iron are more like mild steel. There is a limit to how large a part can be cast in malleable iron, since it is made from white cast iron.

Ductile cast iron

A more recent development is nodular or ductile cast iron. Tiny amounts of magnesium or cerium added to these alloys slow down the growth of graphite precipitates by bonding to the edges of the graphite planes. Along with careful control of other elements and timing, this allows the carbon to separate as spheroidal particles as the material solidifies. The properties are similar to malleable iron, but parts can be cast with larger sections.

TYPICAL USES

Cast iron is used in a wide variety of structural and decorative applications, because it is relatively inexpensive, durable and easily cast into a variety of shapes. Most of the typical uses include:

-  historic markers and plaques
-  hardware: hinges, latches
-  columns, balusters
-  stairs
-  structural connectors in buildings and monuments
-  decorative features
-  fences
-  tools and utensils
-  ordnance
-  stoves and firebacks
-  piping.

The basic cast iron material in all of these applications may appear to be the same, or very similar, however, the component size, composition, use, condition, relationship to adjacent

materials, exposure and other factors may dictate that different treatments be used to correct similar problems. Any material in question should be evaluated as a part of a larger system and treatment plans should be based upon consideration of all relevant factors.

Heat Treatment

Heat Treatment is the controlled heating and cooling of metals to alter their physical and mechanical properties without changing the product shape. Heat treatment is sometimes done inadvertently due to manufacturing processes that either heat or cool the metal such as welding or forming. Heat Treatment is often associated with increasing the strength of material, but it can also be used to alter certain manufacturability objectives such as improve machining, improve formability, restore ductility after a cold working operation. Thus it is a very enabling manufacturing process that can not only help other manufacturing process, but can also improve product performance by increasing strength or other desirable characteristics.

Steels are particularly suitable for heat treatment, since they respond well to heat treatment and the commercial use of steels exceeds that of any other material. Steels are heat treated for one of the following reasons:

1. Softening
2. Hardening
3. Material modification

Softening: Softening is done to reduce strength or hardness, remove residual stresses, improve toughness, restore ductility, refine grain size or change the electromagnetic properties of the steel. Restoring ductility or removing residual stresses is a necessary operation when a large amount of cold working is to be performed, such as in a cold-rolling operation or wire drawing. Annealing — full Process, spheroidizing, normalizing and tempering austempering, martempering are the principal ways by which steel is softened.

Hardening: Hardening of steels is done to increase the strength and wear properties. One of the pre-requisites for hardening is sufficient carbon and alloy content. If there is sufficient Carbon

content then the steel can be directly hardened. Otherwise the surface of the part has to be Carbon enriched using some diffusion treatment hardening techniques.

Material Modification: Heat treatment is used to modify properties of materials in addition to hardening and softening. These processes modify the behavior of the steels in a beneficial manner to maximize service life, e.g., stress relieving, or strength properties, e.g., cryogenic treatment, or some other desirable properties

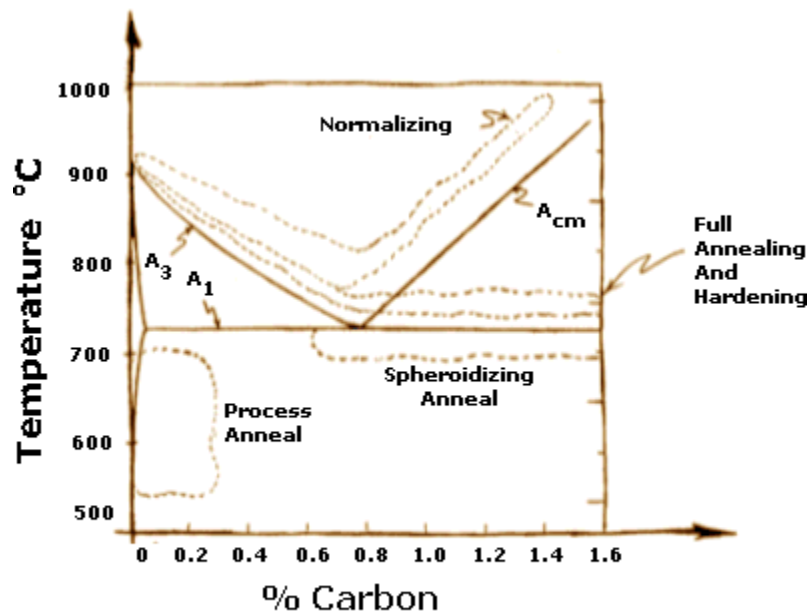

HEAT TREATMENT PROCESS

Full annealing is the process of slowly raising the temperature about 50 °C (90 °F) above the *Austenitic temperature* line A₃ or line A_{CM} in the case of Hypoeutectoid steels (steels with < 0.77% Carbon) and 50 °C (90 °F) into the Austenite-Cementite region in the case of Hypereutectoid steels (steels with > 0.77% Carbon).

It is held at this temperature for sufficient time for all the material to transform into Austenite or Austenite-Cementite as the case may be. It is then slowly cooled at the rate of about 20 °C/hr (36 °F/hr) in a furnace to about 50 °C (90 °F) into the Ferrite-Cementite range. At this point, it can be cooled in room temperature air with natural convection. The grain structure has coarse Pearlite

with ferrite or Cementite (depending on whether hypo or hyper eutectoid). The steel becomes soft and ductile.

Normalizing is the process of raising the temperature to over $60\text{ }^{\circ}\text{C}$ ($108\text{ }^{\circ}\text{F}$), above line A_3 or line A_{CM} fully into the Austenite range. It is held at this temperature to fully convert the structure into Austenite, and then removed from the furnace and cooled at room temperature under natural convection. This results in a grain structure of fine Pearlite with excess of Ferrite or Cementite. The resulting material is soft; the degree of softness depends on the actual ambient conditions of cooling. This process is considerably cheaper than full annealing since there is not the added cost of controlled furnace cooling.

Process Annealing is used to treat work-hardened parts made out of low-Carbon steels ($< 0.25\%$ Carbon). This allows the parts to be soft enough to undergo further cold working without fracturing. Process annealing is done by raising the temperature to just below the Ferrite-Austenite region, line A_1 on the diagram. This temperature is about $727\text{ }^{\circ}\text{C}$ ($1341\text{ }^{\circ}\text{F}$) so heating it to about $700\text{ }^{\circ}\text{C}$ ($1292\text{ }^{\circ}\text{F}$) should suffice. This is held long enough to allow recrystallization of the ferrite phase, and then cooled in still air. Since the material stays in the same phase throughout the process, the only change that occurs is the size, shape and distribution of the grain structure. This process is cheaper than either full annealing or normalizing since the material is not heated to a very high temperature or cooled in a furnace.

Stress Relief Anneal is used to reduce residual stresses in large castings, welded parts and cold-formed parts. Such parts tend to have stresses due to thermal cycling or work hardening. Parts are heated to temperatures of up to $600 - 650\text{ }^{\circ}\text{C}$ ($1112 - 1202\text{ }^{\circ}\text{F}$), and held for an extended time (about 1 hour or more) and then slowly cooled in still air.

Spheroidization is an annealing process used for high carbon steels (Carbon $> 0.6\%$) that will be machined or cold formed subsequently. This is done by one of the following ways:

Heat the part to a temperature just below the Ferrite-Austenite line, line A_1 or below the Austenite-Cementite line, essentially below the $727\text{ }^{\circ}\text{C}$ ($1340\text{ }^{\circ}\text{F}$) line. Hold the temperature for a prolonged time and follow by fairly slow cooling. **Or**

Cycle multiple times between temperatures slightly above and slightly below the 727 °C (1340 °F) line, say for example between 700 and 750 °C (1292 - 1382 °F), and slow cool. **Or**

For tool and alloy steels heat to 750 to 800 °C (1382-1472 °F) and hold for several hours followed by slow cooling.

All these methods result in a structure in which all the Cementite is in the form of small globules (spheroids) dispersed throughout the ferrite matrix. This structure allows for improved machining in continuous cutting operations such as lathes and screw machines. Spheroidization also improves resistance to abrasion.

Tempering is a process done subsequent to quench hardening. Quench-hardened parts are often too brittle. This brittleness is caused by a predominance of Martensite. This brittleness is removed by tempering. Tempering results in a desired combination of hardness, ductility, toughness, strength, and structural stability. Tempering is not to be confused with tempers on rolled stock-these tempers are an indication of the degree of cold work performed.

The mechanism of tempering depends on the steel and the tempering temperature. The prevalent Martensite is a somewhat unstable structure. When heated, the Carbon atoms diffuse from Martensite to form a carbide precipitate and the concurrent formation of Ferrite and Cementite, which is the stable form. Tool steels for example, lose about 2 to 4 points of hardness on the Rockwell C scale. Even though a little strength is sacrificed, toughness (as measured by impact strength) is increased substantially. Springs and such parts need to be much tougher — these are tempered to a much lower hardness.

Tempering is done immediately after quench hardening. When the steel cools to about 40 °C (104 °F) after quenching, it is ready to be tempered. The part is reheated to a temperature of 150 to 400 °C (302 to 752 °F). In this region a softer and tougher structure Troostite is formed. Alternatively, the steel can be heated to a temperature of 400 to 700 °C (752 to 1292 °F) that results in a softer structure known as Sorbite. This has less strength than Troostite but more ductility and toughness.

The heating for tempering is best done by immersing the parts in oil, for tempering upto 350 °C (662 °F) and then heating the oil with the parts to the appropriate temperature. Heating in a bath also ensures that the entire part has the same temperature and will undergo the same tempering. For temperatures above 350 °C (662 °F) it is best to use a bath of nitrate salts. The salt baths can be heated upto 625 °C (1157 °F). Regardless of the bath, gradual heating is important to avoid cracking the steel. After reaching the desired temperature, the parts are held at that temperature for about 2 hours, then removed from the bath and cooled in still air.



CEMENTITE



FERRITE

Hardening

Hardness is a function of the Carbon content of the steel. Hardening of a steel requires a change in structure from the body-centered cubic structure found at room temperature to the face-centered cubic structure found in the Austenitic region. The steel is heated to Austenitic region. When suddenly quenched, the Martensite is formed. This is a very strong and brittle structure. When slowly quenched it would form Austenite and Pearlite which is a partly hard and partly soft structure. When the cooling rate is extremely slow then it would be mostly Pearlite which is extremely soft.

Usually when hot steel is quenched, most of the cooling happens at the surface, as does the hardening. This propagates into the depth of the material. Alloying helps in the hardening and by determining the right alloy one can achieve the desired properties for the particular application.



AUSTENITE



MARTENSITE



CEMENTITE

PEARLITE
COARSEPEARLITE
FINE

Quench Media

Water: Quenching can be done by plunging the hot steel in water. The water adjacent to the hot steel vaporizes, and there is no direct contact of the water with the steel. This slows down cooling until the bubbles break and allow water contact with the hot steel. As the water contacts and boils, a great amount of heat is removed from the steel. With good agitation, bubbles can be prevented from sticking to the steel, and thereby prevent soft spots.

Water is a good rapid quenching medium, provided good agitation is done. However, water is corrosive with steel, and the rapid cooling can sometimes cause distortion or cracking.

Salt Water: Salt water is a more rapid quench medium than plain water because the bubbles are broken easily and allow for rapid cooling of the part. However, salt water is even more corrosive than plain water, and hence must be rinsed off immediately.

Oil: Oil is used when a slower cooling rate is desired. Since oil has a very high boiling point, the transition from start of Martensite formation to the finish is slow and this reduces the likelihood of cracking. Oil quenching results in fumes, spills, and sometimes a fire hazard.

Precipitation hardening is achieved by:

1. solution heat treatment where all the solute atoms are dissolved to form a single-phase solution.
2. rapid cooling across the solvus line to exceed the solubility limit. This leads to a supersaturated solid solution that remains stable (metastable) due to the low temperatures, which prevent diffusion.
3. precipitation heat treatment where the supersaturated solution is heated to an intermediate temperature to induce precipitation and kept there for some time (aging). If the process is continued for a very long time, eventually the hardness decreases. This is called over aging.

The requirements for precipitation hardening are:

- appreciable maximum solubility
- solubility curve that falls fast with temperature
- composition of the alloy that is less than the maximum solubility

Precipitation Hardening

Hardening can be enhanced by extremely small precipitates that hinder dislocation motion. The precipitates form when the solubility limit is exceeded. Precipitation hardening is also called age hardening because it involves the hardening of the material over a prolonged time.

Case Hardening

Case hardening produces a hard, wear-resistant surface or case over a strong, tough core. The principal forms of casehardening are carburizing, cyaniding, and nitriding. Only ferrous metals are case-hardened. Case hardening is ideal for parts that require a wear-resistant surface and must be tough enough internally to withstand heavy loading. The steels best suited for case hardening are the low-carbon and low-alloy series. When high-carbon steels are case hardened, the hardness penetrates the core and causes brittleness. In case hardening, you change the surface of the metal chemically by introducing a high carbide or nitride content. The core remains chemically unaffected. When heat-treated, the high-carbon surface responds to hardening, and the core toughens.

Carburizing

Carburizing is a case-hardening process by which carbon is added to the surface of low-carbon steel. This results in a carburized steel that has a high-carbon surface and a low-carbon interior. When the carburized steel is heat-treated, the case becomes hardened and the core remains soft and tough. Two methods are used for carburizing steel. One method consists of heating the steel in a furnace containing a carbon monoxide atmosphere. The other method has the steel placed in a container packed with charcoal or some other carbon-rich material and then heated in a furnace. To cool the parts, you can leave the container in the furnace to cool or remove it and let it air cool. In both cases, the parts become annealed during the slow cooling. The depth of the carbon penetration depends on the length of the soaking period. With today's methods, carburizing is almost exclusively done by gas atmospheres.

Cyaniding

This process is a type of case hardening that is fast and efficient. Preheated steel is dipped into a heated cyanide bath and allowed to soak. Upon removal, it is quenched and then rinsed to remove any residual cyanide. This process produces a thin, hard shell that is harder than the one produced by carburizing and can be completed in 20 to 30 minutes vice several hours. The major drawback is that cyanide salts are a deadly poison.

Nitriding

This case-hardening method produces the hardest surface of any of the hardening processes. It differs from the other methods in that the individual parts have been heat-treated and tempered before nitriding. The parts are then heated in a furnace that has an ammonia gas atmosphere. No quenching is required so there is no worry about warping or other types of distortion. This process is used to case harden items, such as gears, cylinder sleeves, camshafts and other engine parts, that need to be wear resistant and operate in high-heat areas.

Flame Hardening

Flame hardening is another procedure that is used to harden the surface of metal parts. When you use an oxyacetylene flame, a thin layer at the surface of the part is rapidly heated to its critical temperature and then immediately quenched by a combination of a water spray and the cold base metal. This process produces a thin, hardened surface, and at the same time, the internal parts

retain their original properties. Whether the process is manual or mechanical, a close watch must be maintained, since the torches heat the metal rapidly and the temperatures are usually determined visually. Flame hardening may be either manual or automatic. Automatic equipment produces uniform results and is more desirable. Most automatic machines have variable travel speeds and can be adapted to parts of various sizes and shapes. The size and shape of the torch depends on the part. The torch consists of a mixing head, straight extension tube, 90-degree extension head, an adjustable yoke, and a water-cooled tip. Practically any shape or size flame-hardening tip is available. Tips are produced that can be used for hardening flats, rounds, gears, cams, cylinders, and other regular or irregular shapes. In hardening localized areas, you should heat the metal with a standard hand-held welding torch. Adjust the torch flame to neutral for normal heating; however, in corners and grooves, use a slightly oxidizing flame to keep the torch from sputtering. You also should particularly guard against overheating in corners and grooves. If dark streaks appear on the metal surface, this is a sign of overheating, and you need to increase the distance between the flame and the metal. For the best heating results, hold the torch with the tip of the inner cone about an eighth of an inch from the surface and direct the flame at right angles to the metal. Sometimes it is necessary to change this angle to obtain better results; however, you rarely find a deviation of more than 30 degrees. Regulate the speed of torch travel according to the type of metal, the mass and shape of the part, and the depth of hardness desired. In addition, you must select the steel according to the properties desired. Select carbon steel when surface hardness is the primary factor and alloy steel when the physical properties of the core are also factors. Plain carbon steels should contain more than 0.35% carbon for good results in flame hardening. For water quenching, the effective carbon range is from 0.40% to 0.70%. Parts with a carbon content of more than 0.70% are likely to surface crack unless the heating and quenching rate are carefully controlled. The surface hardness of a flame-hardened section is equal to a section that was hardened by furnace heating and quenching. The decrease in hardness between the case and the core is gradual. Since the core is not affected by flame hardening, there is little danger of spalling or flaking while the part is in use. Thus flame hardening produces a hard case that is highly resistant to wear and a core that retains its original properties. Flame hardening can be divided into five general methods: stationary, circular band progressive, straight-line progressive, spiral band progressive, and circular band spinning.

Diffusion

Diffusion Mechanisms

Diffusion is the process of mass flow in which atoms change their positions relative to neighbors in a given phase under the influence of thermal and a gradient. The gradient can be a compositional gradient, an electric or magnetic gradient, or stress gradient. Many reactions in solids and liquids are diffusion dependent. Diffusion is very important in many industrial and domestic applications. E.g.: Carburizing the steel, annealing homogenization after solidification, coffee mixing, etc. From an atomic perspective, diffusion is a step wise migration of atoms from one lattice position to another. Migration of atoms in metals/alloys can occur in many ways, and thus corresponding diffusion mechanism is defined.

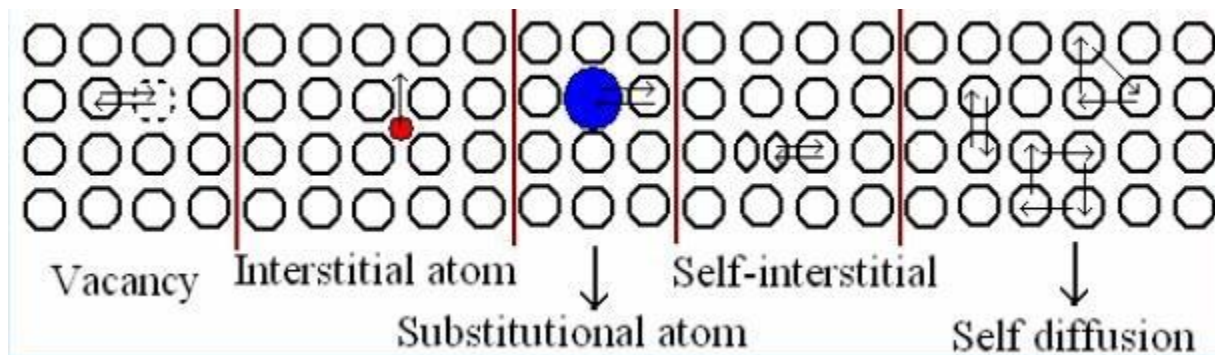

Atom diffusion can occur by the motion of vacancies (vacancy diffusion) or impurities (impurity diffusion). The energy barrier is that due to nearby atoms which need to move to let the atoms go by. This is more easily achieved when the atoms vibrate strongly, that is, at high temperatures. There is a difference between diffusion and net diffusion. In a homogeneous material, atoms also diffuse but this motion is hard to detect. This is because atoms move randomly and there will be an equal number of atoms moving in one direction than in another. In inhomogeneous materials, the effect of diffusion is readily seen by a change in concentration with time. In this case there is a *net* diffusion. Net diffusion occurs because, although all atoms are moving randomly, there are more atoms moving in regions where their concentration is higher.

Steady-State Diffusion

The flux of diffusing atoms, J , is expressed either in number of atoms per unit area and per unit time (e.g., atoms/m²-second) or in terms of mass flux (e.g., kg/m²-second). Steady state diffusion means that J does not depend on time. In this case, *Fick's first law* holds that the flux along direction x is:

$$J = -D \frac{dC}{dx}$$

Where dC/dx is the gradient of the concentration C , and D is the diffusion constant. The concentration gradient is often called the *driving force* in diffusion (but it is not a force in the mechanistic sense). The minus sign in the equation means that diffusion is down the concentration gradient.

Nonsteady-State Diffusion

This is the case when the diffusion flux depends on time, which means that a type of atoms accumulates in a region or that it is depleted from a region (which may cause them to accumulate in another region).

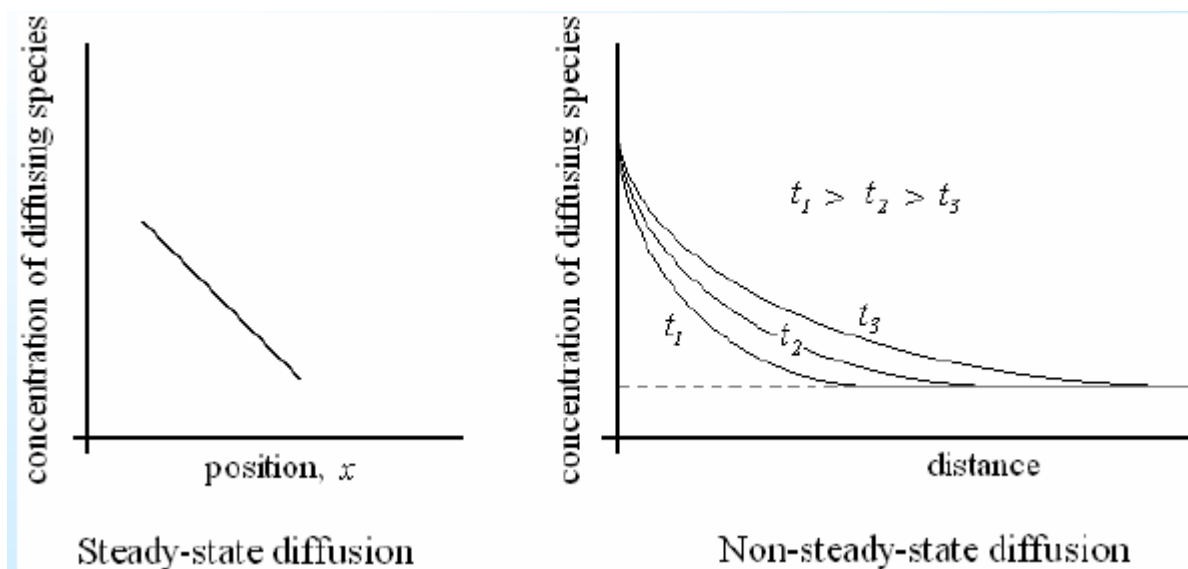

Factors that influence diffusion

As stated above, there is a barrier to diffusion created by neighboring atoms that need to move to let the diffusing atom pass. Thus, atomic vibrations created by temperature assist diffusion. Also, smaller atoms diffuse more readily than big ones, and diffusion is faster in open lattices or in

open directions. Similar to the case of vacancy formation, the effect of temperature in diffusion is given by a Boltzmann factor: $D = D_0 \times \exp(-Q_d/kT)$.

NON FERROUS METAL & ALLOYS

Copper

- ❖ Copper is one of the earliest metals discovered by man.
- ❖ The boilers on early steamboats were made from copper.
- ❖ The copper tubing used in water plumbing in Pyramids was found in serviceable condition after more than 5,000 years.
- ❖ Cu is a ductile metal. Pure Cu is soft and malleable, difficult to machine.
- ❖ Very high electrical conductivity – second only to silver.
- ❖ Copper is refined to high purity for many electrical





Applications

















- Excellent thermal conductivity – Copper cookware most highly regarded – fast and uniform heating.
- Electrical and construction industries are the largest users of Cu.

Copper Alloys

- Brasses and Bronzes are most commonly used alloys of Cu. Brass is an alloy with Zn. Bronzes contain tin, aluminum, silicon or beryllium.
- Other copper alloy families include copper-nickels and nickel silvers. More than 400 copper-base alloys are recognized.

Applications

-  Electrical wires,
-  roofing, nails, rivets
-  Automotive radiator
-  core, lamp fixture,



















-  clutch disk,
-  diaphragm, fuse clips,
-  springs
-  Furniture, radiator
-  fittings, battery clamps,
-  light fixtures
-  Bearings, bushings,
-  valve seats and guards
-  Electrical, valves,
-  pumps
-  Condenser, heat exchanger
-  piping,
-  valves
-  Tin bronze Sn,
-  Bearings, bushing,
-  piston rings, gears

Aluminum

- Aluminum is a light metal & easily machinable; has wide variety of surface finishes; good electrical and thermal conductivities; highly reflective to heat and light.
- Versatile metal - can be cast, rolled, stamped, drawn, spun, roll-formed, hammered, extruded and forged into many shapes.
- Aluminum can be riveted, welded, brazed, or resin bonded.
- Corrosion resistant - no protective coating needed, however it is often anodized to improve surface finish, appearance.
- Al and its alloys - high strength-to-weight ratio (high specific strength) owing to low density.
- Such materials are widely used in aerospace and automotive applications where weight savings are needed for better fuel efficiency and performance.

- Al-Li alloys are lightest among all Al alloys and find wide applications in the aerospace industry.

Application of some Al Alloys

-  Food/chemical handling
 -  equipment, heat exchangers
 -  light reflectors
 -  Utensils, pressure vessels and
 -  piping
 -  Strain-hardn.
 -  Bellows, clutch disk,
 -  diaphragm, fuse clips, springs
 -  Heat treated
 -  Aircraft structure, rivets, truck
 -  wheels, screw
 -  Trucks, canoes, railroad cars,
 -  furniture, pipelines
 -  Peak-aged
 -  Aircraft structures and other
 -  highly loaded applications
 -  Aircraft pump parts,
 -  automotive transmission
 -  cases, cylinder blocks

Zinc

Zinc (symbol Zn), in commerce also spelter, is a metallic chemical element. It has atomic number 30. It is the first element of group 12 of the periodic table. In some respects zinc is chemically similar to magnesium: its ion is of similar size and its only common oxidation state is +2. Zinc is the 24th most abundant element in the Earth's crust and has five stable isotopes. The most common zinc ore is sphalerite (zinc blende), a zinc sulfide mineral. The largest mineable amounts are found in Australia, Asia, and the United States. Zinc production includes froth flotation of the ore, roasting, and final extraction using electricity (electrowinning).

Brass, which is an alloy of copper and zinc, has been used since at least the 10th century BC in Judea and by the 7th century BC in Ancient Greece. Zinc metal was not produced on a large scale until the 12th century in India and was unknown to Europe until the end of the 16th century. The mines of Rajasthan have given definite evidence of zinc production going back to 6th century BC. To date, the oldest evidence of pure zinc comes from Zawar, in Rajasthan, as early as the 9th century AD when a distillation process was employed to make pure zinc. Alchemists burned zinc in air to form what they called "philosopher's wool" or "white snow".

Applications

Major applications of zinc include

- Galvanizing (55%)
- Alloys (21%)
- Brass and bronze (16%)
- Miscellaneous (8%)

The metal is most commonly used as an anti-corrosion agent. Galvanization, which is the coating of iron or steel to protect the metals against corrosion, is the most familiar form of using zinc in this way. In 2009 in the United States, 55% or 893 thousand tonnes of the zinc metal was used for galvanization.

Zinc is more reactive than iron or steel and thus will attract almost all local oxidation until it completely corrodes away. A protective surface layer of oxide and carbonate forms as the zinc corrodes. This protection lasts even after the zinc layer is scratched but degrades through time as

the zinc corrodes away. The zinc is applied electrochemically or as molten zinc by hot-dip galvanizing or spraying. Galvanization is used on chain-link fencing, guard rails, suspension bridges, light posts, metal roofs, heat exchangers, and car bodies.

The relative reactivity of zinc and its ability to attract oxidation to itself makes it an efficient sacrificial anode in cathodic protection (CP). For example, cathodic protection of a buried pipeline can be achieved by connecting anodes made from zinc to the pipe. Zinc acts as the anode (negative terminus) by slowly corroding away as it passes electric current to the steel pipeline. Zinc is also used to cathodically protect metals that are exposed to sea water from corrosion. A zinc disc attached to a ship's iron rudder will slowly corrode while the rudder stays unattacked. Other similar uses include a plug of zinc attached to a propeller or the metal protective guard for the keel of the ship.

With a standard electrode potential (SEP) of -0.76 volts, zinc is used as an anode material for batteries. (More reactive lithium (SEP -3.04 V) is used for anodes in lithium batteries). Powdered zinc is used in this way in alkaline batteries and sheets of zinc metal form the cases for and act as anodes in zinc-carbon batteries.[98][99] Zinc is used as the anode or fuel of the zinc-air battery/fuel cell. The zinc-cerium redox flow battery also relies on a zinc-based negative half-cell.

Alloys

A widely used alloy which contains zinc is brass, in which copper is alloyed with anywhere from 3% to 45% zinc, depending upon the type of brass. Brass is generally more ductile and stronger than copper and has superior corrosion resistance. These properties make it useful in communication equipment, hardware, musical instruments, and water valves.

Other widely used alloys that contain zinc include nickel silver, typewriter metal, soft and aluminium solder, and commercial bronze. Zinc is also used in contemporary pipe organs as a substitute for the traditional lead/tin alloy in pipes.[104] Alloys of 85–88% zinc, 4–10% copper, and 2–8% aluminium find limited use in certain types of machine bearings. Zinc is the primary metal used in making American one cent coins since 1982. The zinc core is coated with a thin layer of copper to give the impression of a copper coin. In 1994, 33,200 tonnes (36,600 short tons) of zinc were used to produce 13.6 billion pennies in the United States. Alloys of primarily

zinc with small amounts of copper, aluminium, and magnesium are useful in die casting as well as spin casting, especially in the automotive, electrical, and hardware industries. These alloys are marketed under the name Zamak. An example of this is zinc aluminium. The low melting point together with the low viscosity of the alloy makes the production of small and intricate shapes possible. The low working temperature leads to rapid cooling of the cast products and therefore fast assembly is possible. Another alloy, marketed under the brand name Prestal, contains 78% zinc and 22% aluminium and is reported to be nearly as strong as steel but as malleable as plastic. This superplasticity of the alloy allows it to be molded using die casts made of ceramics and cement.

Similar alloys with the addition of a small amount of lead can be cold-rolled into sheets. An alloy of 96% zinc and 4% aluminium is used to make stamping dies for low production run applications for which ferrous metal dies would be too expensive. In building facades, roofs or other applications in which zinc is used as sheet metal and for methods such as deep drawing, roll forming or bending, zinc alloys with titanium and copper are used. Unalloyed zinc is too brittle for these kinds of manufacturing processes.

As a dense, inexpensive, easily worked material, zinc is used as a lead replacement. In the wake of lead concerns, zinc appears in weights for various applications ranging from fishing to tire balances and flywheels.

Cadmium zinc telluride (CZT) is a semi conductive alloy that can be divided into an array of small sensing devices. These devices are similar to an integrated circuit and can detect the energy of incoming gamma ray photons. When placed behind an absorbing mask, the CZT sensor array can also be used to determine the direction of the rays.

Other industrial uses

Zinc oxide is used as a white pigment in paints. Roughly one quarter of all zinc output in the United States (2009), is consumed in the form of zinc compounds; a variety of which are used industrially. Zinc oxide is widely used as a white pigment in paints, and as a catalyst in the manufacture of rubber. It is also used as a heat disperser for the rubber and acts to protect its polymers from ultraviolet radiation (the same UV protection is conferred to plastics containing zinc oxide). The semiconductor properties of zinc oxide make it useful in varistors and

photocopying products. The zinc zinc-oxide cycle is a two step thermochemical process based on zinc and zinc oxide for hydrogen production.

Zinc chloride is often added to lumber as a fire retardant and can be used as a wood preservative. It is also used to make other chemicals.

Crystals of ZnS are used in lasers that operate in the mid-infrared part of the spectrum. Zinc sulfide is a chemical in dyes and pigments. Zinc pyrithione is used in antifouling paints.

Zinc powder is sometimes used as a propellant in model rockets. When a compressed mixture of 70% zinc and 30% sulfur powder is ignited there is a violent chemical reaction. This produces zinc sulfide, together with large amounts of hot gas, heat, and light. Zinc sheet metal is used to make zinc bars.

Zn, the most abundant isotope of zinc, is very susceptible to neutron activation, being transmuted into the highly radioactive

Zn, which has a half-life of 244 days and produces intense gamma radiation. Because of this, Zinc Oxide used in nuclear reactors as an anti-corrosion agent is depleted of

Zn before use, this is called depleted zinc oxide. For the same reason, zinc has been proposed as a salting material for nuclear weapons (cobalt is another, better-known salting material). A jacket of isotopically enriched

Zn would be irradiated by the intense high-energy neutron flux from an exploding thermonuclear weapon, forming a large amount of

Zn significantly increasing the radioactivity of the weapon's fallout. Such a weapon is not known to have ever been built, tested, or used.

Zn is also used as a tracer to study how alloys that contain zinc wear out, or the path and the role of zinc in organisms.

Chromium

Chromium is a chemical element which has the symbol Cr and atomic number 24. It is the first element in Group 6. It is a steely-gray, lustrous, hard and brittle metal which takes a high polish,

resists tarnishing, and has a high melting point. Chromium oxide was used by the Chinese in the Qin dynasty over 2,000 years ago to coat metal weapons found with the Terracotta Army. Chromium was discovered as an element after it came to the attention of the western world in the red crystalline mineral crocoite (lead(II) chromate), discovered in 1761 and initially used as a pigment. Louis Nicolas Vauquelin first isolated chromium metal from this mineral in 1797. Since Vauquelin's first production of metallic chromium, small amounts of native (free) chromium metal have been discovered in rare minerals, but these are not used commercially. Instead, nearly all chromium is commercially extracted from the single commercially viable orechromite, which is iron chromium oxide Chromite is also now the chief source of chromium for chromium pigments.

Applications

The strengthening effect of forming stable metal carbides at the grain boundaries and the strong increase in corrosion resistance made chromium an important alloying material for steel. The high-speed tool steels contain between 3 and 5% chromium. Stainless steel, the main corrosion-proof metal alloy, is formed when chromium is added to iron in sufficient concentrations, usually above 11%. For its formation, ferrochromium is added to the molten iron. Also nickel-based alloys increase in strength due to the formation of discrete, stable metal carbide particles at the grain boundaries. For example, Inconel 718 contains 18.6% chromium. Because of the excellent high-temperature properties of these nickel superalloys, they are used in jet engines and gas turbines in lieu of common structural materials.

The relative high hardness and corrosion resistance of unalloyed chromium makes it a good surface coating, being still the most "popular" metal coating with unparalleled combined durability. A thin layer of chromium is deposited on pretreated metallic surfaces by electroplating techniques. There are two deposition methods: Thin, below 1 μm thickness, layers are deposited by chrome plating, and are used for decorative surfaces. If wear-resistant surfaces are needed then thicker chromium layers are deposited. Both methods normally use acidic chromate or dichromate solutions. To prevent the energy-consuming change in oxidation state, the use of chromium(III) sulfate is under development, but for most applications, the established process is used.

In the chromate conversion coating process, the strong oxidative properties of chromates are used to deposit a protective oxide layer on metals like aluminium, zinc and cadmium. This passivation and the self-healing properties by the chromate stored in the chromate conversion coating, which is able to migrate to local defects, are the benefits of this coating method. Because of environmental and health regulations on chromates, alternative coating methods are under development.

Anodizing of aluminium is another electrochemical process, which does not lead to the deposition of chromium, but uses chromic acid as electrolyte in the solution. During anodization, an oxide layer is formed on the aluminium. The use of chromic acid, instead of the normally used sulfuric acid, leads to a slight difference of these oxide layers. The high toxicity of Cr(VI) compounds, used in the established chromium electroplating process, and the strengthening of safety and environmental regulations demand a search for substitutes for chromium or at least a change to less toxic chromium(III) compounds.

Dye and pigment

The mineral crocoite (lead chromate PbCrO_4) was used as a yellow pigment shortly after its discovery. After a synthesis method became available starting from the more abundant chromite, chrome yellow was, together with cadmium yellow, one of the most used yellow pigments. Chromium oxides are also used as a green color in glassmaking and as a glaze in ceramics. Green chromium oxide is extremely light-fast and as such is used in cladding coatings. It is also the main ingredient in IR reflecting paints, used by the armed forces, to paint vehicles, to give them the same IR reflectance as green leaves.

Synthetic ruby and the first laser

Natural rubies are corundum (aluminum oxide) crystals that are colored red (the rarest type) due to chromium (III) ions (other colors of corundum gems are termed sapphires). A red-colored artificial ruby may also be achieved by doping chromium(III) into artificial corundum crystals, thus making chromium a requirement for making synthetic rubies.

Wood preservative

Because of their toxicity, chromium(VI) salts are used for the preservation of wood. For example, chromated copper arsenate (CCA) is used in timber treatment to protect wood from decay fungi, wood attacking insects, including termites, and marine borers

Refractory material

The high heat resistivity and high melting point makes chromite and chromium(III) oxide a material for high temperature refractory applications, like blast furnaces, cement kilns, molds for the firing of bricks and as foundry sands for the casting of metals. In these applications, the refractory materials are made from mixtures of chromite and magnesite. The use is declining because of the environmental regulations due to the possibility of the formation of chromium(VI).

Brasses & Bronzes

Brass is an alloy made of copper and zinc; the proportions of zinc and copper can be varied to create a range of brasses with varying properties. Bronze is an alloy consisting primarily of copper, usually with tin as the main additive. It is hard and tough, and it was so significant in antiquity that the Bronze Age was named after the metal.

Admiralty brass contains 30% zinc, with 1% tin to inhibit dezincification in many environments. Alpha brasses with less than 35% zinc, are malleable, can be worked cold, and are used in pressing, forging, or similar applications. They contain only one phase, with face-centered cubic crystal structure. Alpha-beta brass (Muntz metal), also called duplex brass, is 35–45% zinc and is suited for hot working. It contains both α and β' phase; the β' -phase is body-centered cubic and is harder and stronger than α . Alpha-beta brasses are usually worked hot. Aluminium brass contains aluminium, which improves its corrosion resistance. Red brass is both an American term for the copper-zinc-tin alloy known as gunmetal, and an alloy which is considered both a brass and a bronze. It typically contains 85% copper, 5% tin, 5% lead, and 5% zinc.

Aluminium Bronze

A type of BRONZE in which aluminium is the main alloying metal added to copper. Small amounts of other elements such as iron, manganese, nickel and silicon are added to impart

various properties such as corrosion resistance or malubility. It fairs well in the marine enviroment.

Typical compostion:

Copper 80%

Aluminium 10%

Nickel 5%

Iron 5%

Silicon Bronze

Has small amounts of silicon to allow it to be wrought or cold worked into a stronger alloy such as by rolling. It is also resistant to corrosion and therefore good for use in the marine enviroment.

Typical compostion:

Copper 96%

Silicon 3%

Manganase 1%

Phosphor bronze

Well this one is different! Rather than Phosphor being the main alloy metal, it is used during manufacture to purify the melt and create a purer stronger type of bronze. Usually not more than 0.2% of the Phosphur is left in the metal. It is very corrosion resistant and therefore good in the marine environment.

Typical compostion:

Copper 94.8%

Tin 5%

Phosphorus 0.2%

Leaded Bronze

Leaded Gunmetal (LG2) Is a type of copper alloy that has a small amount of lead, tin and zinc added in similar quantities. It is not considered to be brass due to the amount of zinc being small. It has widespread use as a valve and through hull fitting material due to it's good seawater resistance. It does not de-zincify in seawater despite having a zinc content. It is good for use in the marine environment.

Typical composition:

Copper 85%

Lead 5%

Tin 5%

Zinc 5%

Bronze was especially suitable for use in boat and ship fittings prior to the wide employment of stainless steel owing to its combination of toughness and resistance to salt water corrosion. Bronze is still commonly used in ship propellers and submerged bearings.

In the 20th century, silicon was introduced as the primary alloying element, creating an alloy with wide application in industry and the major form used in contemporary statuary. Sculptors may prefer silicon bronze because of the ready availability of silicon bronze brazing rod, which allows color-matched repair of defects in castings. Aluminium is also used for the structural metal aluminium bronze.

It is also widely used for cast bronze sculpture. Many common bronze alloys have the unusual and very desirable property of expanding slightly just before they set, thus filling in the finest details of a mold. Bronze parts are tough and typically used for bearings, clips, electrical connectors and springs.

Bronze also has very low metal-on-metal friction, which made it invaluable for the building of cannon where iron cannonballs would otherwise stick in the barrel. It is still widely used today for springs, bearings, bushings, automobile transmission pilot bearings, and similar fittings, and is particularly common in the bearings of small electric motors. Phosphor bronze is particularly suited to precision-grade bearings and springs. It is also used in guitar and piano strings.

Unlike steel, bronze struck against a hard surface will not generate sparks, so it (along with beryllium copper) is used to make hammers, mallets, wrenches and other durable tools to be used in explosive atmospheres or in the presence of flammable vapors.

Bronze is used to make bronze wool for woodworking applications where steel wool would discolor oak.

Bearing Materials - Ceramics, Chrome Steels, Stainless Steels, and Plastics

The bearing industry uses different materials for the production of the various bearing components. The materials are processed to achieve desirable properties to maximize bearing performance and life. The materials described here are the most commonly used. Additional information can be found in the Technical Information Sheets for Balls, Closures, and Retainers.

MODULE V

Dielectric Materials

A dielectric material (dielectric for short) is an electrical insulator that can be polarized by an applied electric field. When a dielectric is placed in an electric field, electric charges do not flow through the material as they do in a conductor, but only slightly shift from their average equilibrium positions causing dielectric polarization. Because of dielectric polarization, positive charges are displaced toward the field and negative charges shift in the opposite direction. This creates an internal electric field that reduces the overall field within the dielectric itself. If a dielectric is composed of weakly bonded molecules, those molecules not only become polarized, but also reorient so that their symmetry axes align to the field.

The study of dielectric properties concerns storage and dissipation of electric and magnetic energy in materials. Dielectrics are important for explaining various phenomena in electronics, optics, and solid-state physics.

Dielectric strength

All insulating materials fail at some level of applied voltage, and ‘dielectric strength’ is the voltage a material can withstand before breakdown occurs. Dielectric strength is measured through the thickness of the material (taking care to avoid surface effects) and is normally expressed as a voltage gradient (volts per unit length). Note that the voltage gradient at breakdown is much higher for very thin test pieces (<100 μ m thick) than for thicker sections.

The value of dielectric strength for a specimen is also influenced by its temperature and ambient humidity, by any voids or foreign materials in the specimen, and by the conditions of test, so that it is often difficult to compare data from different sources.

Test variables include electrode configuration and specimen geometry, and the frequency and rate of application of the test voltage. Standard strategies include:

- The ‘short-time’ test, increasing the voltage from zero at a predetermined rate (usually between 100 and 3,000V/sec) until breakdown occurs
- The ‘step-by-step’ test, initially applying half the short-time breakdown voltage, and then increasing this in equal increments, holding each level for a set period of time.

Intrinsic dielectric strength

Another test term sometimes used is ‘intrinsic dielectric strength’, which is the maximum voltage gradient a homogeneous substance will withstand in a uniform electric field. This shows the ability of an insulating material to resist breakdown, but practical tests produce lower values for a number of reasons:

- Defects, voids, and foreign particles introduced during manufacture which lower the dielectric strength locally, having the effect of reducing the test values as the area tested is increased
- The presence of a stress concentration at the electrode edges or points where the electric field is higher than average.
- Due to the damaging effect of an electric discharge during testing
- Because of dielectric heating, which raises the temperature and lowers the breakdown strength.

Magnetic Properties

Diamagnetism is a very weak form of magnetism that is nonpermanent and persists only while an external field is being applied. It is induced by a change in the orbital motion of electrons due to an applied magnetic field. The magnitude of the induced magnetic moment is extremely small and in a direction opposite to that of the applied field. Most elements in the periodic table, including copper, silver, and gold, are diamagnetic.

Paramagnetic material is one whose atoms do have permanent dipole moments, but the magic of ferromagnetism is not active. If a magnetic field is applied to such a material, the dipole moments try to line up with the magnetic field, but are prevented from becoming perfectly aligned by their random thermal motion. Because the dipoles try to line up with the applied field, the susceptibilities of such materials are positive, but in the absence of the strong ferromagnetic effect, the susceptibilities are rather small, say in the range to . When a paramagnetic material is placed in a strong magnetic field, it becomes a magnet, and as long as the strong magnetic field is present, it will attract and repel other magnets in the usual way. But when the strong magnetic field is removed, the net magnetic alignment is lost as the dipoles relax back to their normal

random motion. Paramagnetic materials include magnesium, molybdenum, lithium, and tantalum.

Ferromagnetism:

Certain metallic materials possess a permanent magnetic moment in the absence of an external field, and manifest very large and permanent magnetizations. These are the characteristics of ferromagnetism, and they are displayed by the transition metals iron, cobalt, nickel, and some of the rare earth metals. Permanent magnetic moments in ferromagnetic materials result from atomic magnetic moments due to electron spinuncancelled electron spins as a consequence of the electron structure. There is also an orbital magnetic moments contribution that is small in comparison to the spin moment. Furthermore, in a ferromagnetic material, coupling interactions cause net spin magnetic moments of adjacent atoms to align with one another, even in the absence of an external field. The maximum possible magnetization or saturation magnetization M_s of a ferromagnetic material represents the magnetization that results when all the magnetic dipoles in a solid piece are mutually aligned with the external field; there is also a corresponding saturation flux density B_s . Iron, nickel, and cobalt are examples of ferromagnetic materials.

Antiferromagnetism:

This phenomenon of magnetic moment coupling between adjacent atoms or ions occurs in materials other than those that are ferromagnetic. In one such group, this coupling results in an antiparallel alignment; the alignment of the spin moments of neighbouring atoms or ions in exactly opposite directions is termed antiferromagnetism. Manganese Oxide (MnO) is one such material that displays this behavior. Manganese oxide is a ceramic material that is ionic in character, having both Mn and O ions. No net magnetic moment is associated with O ions, since there is a total cancellation of both spin and orbital moments. However, the Mn ions possess a net magnetic moment that is Material predominantly of spin origin. These Mn ions are arrayed in the crystal structure such that the moments of adjacent ions are antiparallel. Obviously, the opposing magnetic moments cancel one another and as a consequence, the solid as a whole possesses no net magnetic moment.

Ferrimagnetism

Some ceramics also exhibit a permanent magnetizations termed ferrimagnetism. The macroscopic magnetic characteristics of ferromagnets and ferrimagnets are similar; the distinction lies in the source of the net magnetic moments. The net ferrimagnetic moment arises from the incomplete cancellation of spin moments.

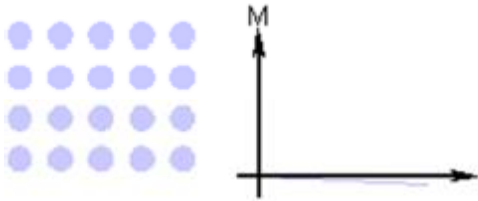
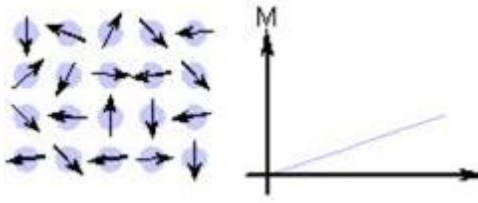
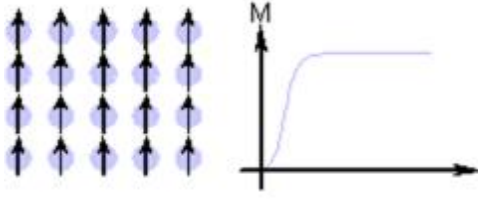
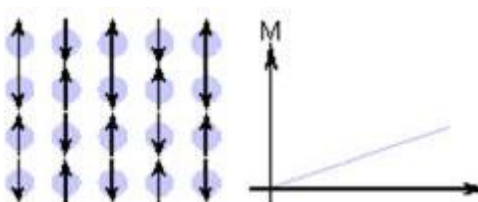
Type of Magnetism	Susceptibility	Atomic / Magnetic Behaviour	Example / Susceptibility
Diamagnetism	Small & negative.	Atoms have no magnetic moment 	- 2.74×10^{-6} Au $-$ 0.77×10^{-6} Cu
Paramagnetism	Small & positive.	Atoms have randomly oriented magnetic moments 	0.19×10^{-6} β -Sn Pt 21.04×10^{-6} Mn 66.10×10^{-6}
Ferromagnetism	Large & positive, function of applied field, microstructure dependent.	Atoms have parallel aligned magnetic moments 	Fe $\sim 100,000$
Antiferromagnetism	Small & positive.	Atoms have mixed parallel and anti-parallel aligned Magnetic Moments 	Cr 3.6×10^{-6}

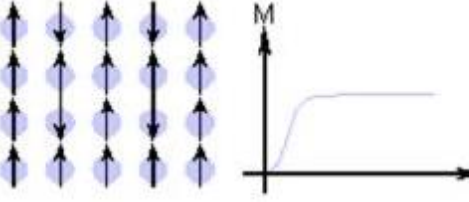
Ferrimagnetism	Large & positive, function of applied field, microstructure dependent	Atoms have anti-parallel aligned magnetic moments	 <p>The diagram shows a 3x5 grid of atoms. Each atom is represented by a blue circle with a vertical arrow. The arrows in the first column point up, the second column down, the third column up, the fourth column down, and the fifth column up. To the right of the grid is a graph with a vertical axis labeled 'M' and a horizontal axis. The curve starts at the origin, rises steeply, and then levels off to a horizontal line, representing a magnetization curve for a ferrimagnetic material.</p>	Ba ferrite ~3
----------------	-----------------------------------------------------------------------	---------------------------------------------------	------------------------------------------------------------------------------------------------------------------------------------------------------------------------------------------------------------------------------------------------------------------------------------------------------------------------------------------------------------------------------------------------------------------------------------------------------------------------------------------------------------------------------------------------------------------------------------------------	------------------

Summary of different types of magnetic behaviour.

Hard Magnetic Materials

Hard magnets, also referred to as permanent magnets, are magnetic materials that retain their magnetism after being magnetised. Practically, this means materials that have an intrinsic coercivity of greater than $\sim 10 \text{kA m}^{-1}$.

It is believed that permanent magnets have been used for compasses by the Chinese since $\sim 2500 \text{BC}$. However, it was only in the early twentieth century that high carbon steels and then tungsten / chromium containing steels replaced lodestone as the best available permanent magnet material. These magnets were permanent magnets due to the pinning of domain walls by dislocations and inclusions. The movement of dislocations within a material is often hindered by the same factors that effect the motion of domain walls and as a consequence these steels are mechanically very hard and are the origin of the term hard magnetic. These magnets had an energy product of approximately 8kJ m^{-3}

Soft Magnetic Materials

Soft magnetic materials are those materials that are easily magnetised and demagnetised. They typically have intrinsic coercivity less than 1000 A m^{-1} . They are used primarily to enhance and/or channel the flux produced by an electric current. The main parameter, often used as a figure of merit for soft magnetic materials, is the relative permeability (m_r , where $m_r = B/m_o H$), which is a measure of how readily the material responds to the applied magnetic field. The other main parameters of interest are the coercivity, the saturation magnetisation and the electrical conductivity.

Influence of temperature on magnetic behavior:

Temperature can also influence the magnetic characteristics of materials. The atomic magnetic moments are free to rotate, hence with rising temperature, the increased thermal motion of the atoms tends to randomize the directions of any moments that may be aligned.

For ferromagnetic, antiferromagnetic and ferrimagnetic materials, the atomic thermal motions counteract the coupling forces between the adjacent atomic dipole moments, causing some dipole misalignment, regardless of whether an external field is present. The result is a decrease in the saturation magnetization for both ferro and ferrimagnets. The saturation magnetization is a maximum at 0 K, at which temperature the thermal vibrations are a minimum. With increasing temperature, the saturation magnetization diminishes gradually and then abruptly drops to zero at what is called the Curie temperature T_c . The magnitude of the Curie temperature varies from material to material; for example, for iron, cobalt, nickel, the respective values are 768, 1120, 335 and 585 degree Celsius. Antiferromagnetism is also affected by temperature; this behavior vanishes at what is called the Neel temperature. At temperatures above this point, antiferromagnetic materials also become paramagnetic.

Domains and Hysteresis:

Any ferromagnetic or ferrimagnetic material that is at a temperature below T_c is composed of small-volume regions in which there is a mutual alignment in the same direction of all magnetic dipole moments. Such a region is called a domain, and each one is magnetized to its saturation magnetization. Adjacent domains are separated by domain boundaries or walls across which the direction of magnetization gradually changes. Normally, domains are microscopic in size and for a polycrystalline specimen, each grain may consist of a single domain. Thus, in a microscopic piece of material, there will be large number of domains and all may have different magnetization orientations.

The Hysteresis Loop and Magnetic Properties

A great deal of information can be learned about the magnetic properties of a material by studying its hysteresis loop. A hysteresis loop shows the relationship between the induced magnetic flux density (**B**) and the magnetizing force (**H**). It is often referred to as the B-H loop. An example hysteresis loop is shown below.

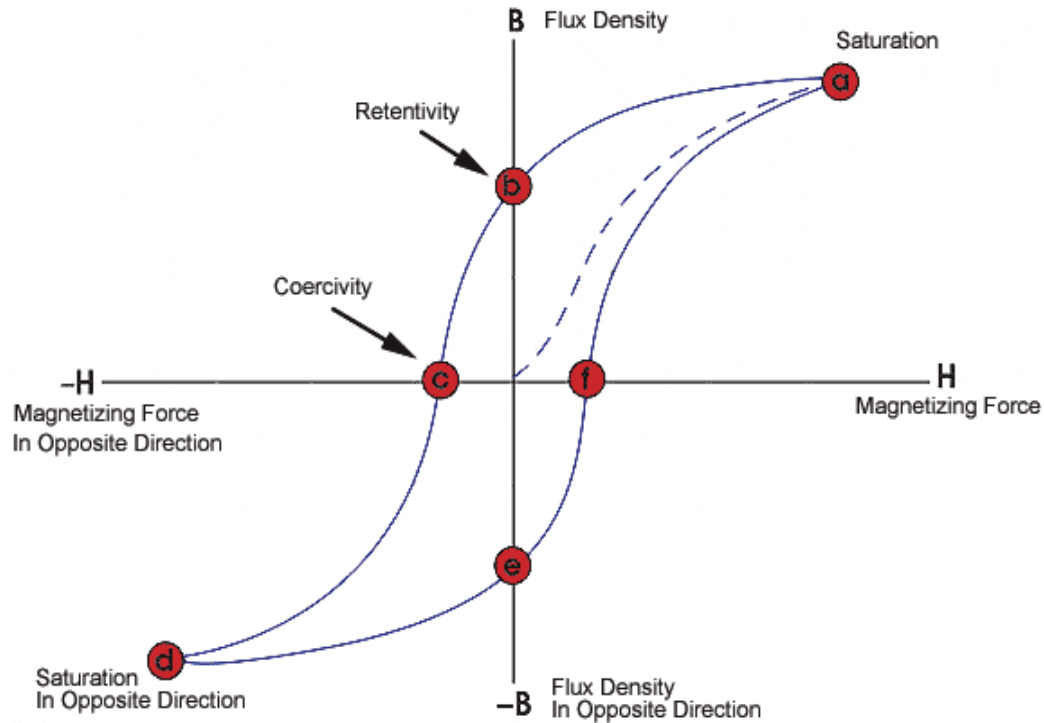

The loop is generated by measuring the magnetic flux of a ferromagnetic material while the magnetizing force is changed. A ferromagnetic material that has never been previously magnetized or has been thoroughly demagnetized will follow the dashed line as H is increased. As the line demonstrates, the greater the amount of current applied ($H+$), the stronger the magnetic field in the component ($B+$). At point "a" almost all of the magnetic domains are aligned and an additional increase in the magnetizing force will produce very little increase in magnetic flux. The material has reached the point of magnetic saturation. When H is reduced to zero, the curve will move from point "a" to point "b." At this point, it can be seen that some magnetic flux remains in the material even though the magnetizing force is zero. This is referred to as the point of retentivity on the graph and indicates the remanence or level of residual magnetism in the material. (Some of the magnetic domains remain aligned but some have lost their alignment.) As the magnetizing force is reversed, the curve moves to point "c", where the flux has been reduced to zero. This is called the point of coercivity on the curve. (The reversed magnetizing force has flipped enough of the domains so that the net flux within the material is zero.) The force required to remove the residual magnetism from the material is called the coercive force or coercivity of the material.

As the magnetizing force is increased in the negative direction, the material will again become magnetically saturated but in the opposite direction (point "d"). Reducing \mathbf{H} to zero brings the curve to point "e." It will have a level of residual magnetism equal to that achieved in the other direction. Increasing \mathbf{H} back in the positive direction will return \mathbf{B} to zero. Notice that the curve did not return to the origin of the graph because some force is required to remove the residual magnetism. The curve will take a different path from point "f" back to the saturation point where it will complete the loop.

From the hysteresis loop, a number of primary magnetic properties of a material can be determined.

1. **Retentivity** - A measure of the residual flux density corresponding to the saturation induction of a magnetic material. In other words, it is a material's ability to retain a certain amount of residual magnetic field when the magnetizing force is removed after achieving saturation. (The value of \mathbf{B} at point b on the hysteresis curve.)
2. **Residual Magnetism** or **Residual Flux** - the magnetic flux density that remains in a material when the magnetizing force is zero. Note that residual magnetism and retentivity are the same when the material has been magnetized to the saturation point. However, the level of residual magnetism may be lower than the retentivity value when the magnetizing force did not reach the saturation level.
3. **Coercive Force** - The amount of reverse magnetic field which must be applied to a magnetic material to make the magnetic flux return to zero. (The value of \mathbf{H} at point c on the hysteresis curve.)
4. **Permeability** - A property of a material that describes the ease with which a magnetic flux is established in the component.

Magnetic Tapes: Magnetic tapes are extensively used for recording audio and video signals, although it is unclear how long this technology will continue to be used with the rising popularity of the digital versatile disk (DVD).

Tapes can be made with either a particulate media adhered to a plastic substrate or a metal evaporated (ME) film on the substrate. The magnetic layer on a particulate tape is only 40% magnetic material whereas ME tapes have a 100% magnetic layer. Therefore, ME tapes give

better quality recording, but they are more time consuming to produce and are more expensive. Particulate tapes are much cheaper and hence account for the majority of magnetic tapes.

Magnetic Disks: Recording data onto a disk has obvious advantages with respect to access times, as the head can readily be moved to the appropriate place on the disk whereas a tape would need to be rewound or advanced. There are two types of disk: floppy and hard. The principles of manufacturing and recording on floppy disks are very similar to that of particulate magnetic tape, i.e. the same particulate materials on a plastic substrates.

Hard disk drives are formed on a rigid substrate, usually aluminium, which is around 2mm thick. On to the substrate are deposited several layers: an under layer to help adhesion (~10nm nickel phosphide); a layer of chromium (5-10nm) to control orientation and grain size of magnetic layer; the magnetic layer (50nm PtCo with various additions of Ta, P, Ni, Cr); a protective overcoat (e.g. 10-20nm zirconia) and finally lubricant to reduce friction and wear of the disk (e.g. a monolayer of long chain fluorocarbons). The magnetic layer forms a cellular structure of Co-rich magnetic cells in a non-magnetic matrix. These cells act just like particulate recording media but on a much finer scale.

Electrical Properties

Electronic and Ionic Conduction

In metals, the current is carried by electrons, and hence the name *electronic conduction*. In ionic crystals, the charge carriers are ions, thus the name *ionic conduction*.

Energy Band Structures in Solids





When atoms come together to form a solid, their valence electrons interact due to Coulomb forces, and they also feel the electric field produced by their own nucleus and that of the other atoms. In addition, two specific quantum mechanical effects happen. First, by Heisenberg's uncertainty principle, constraining the electrons to a small volume raises their energy, this is called *promotion*. The second effect, due to the Pauli Exclusion Principle, limits the number of electrons that can have the same property (which include the energy). As a result of all these effects, the valence electrons of atoms form wide valence bands when they form a solid. The bands are separated by gaps, where electrons cannot exist. The precise location of the bands and

band gaps depends on the type of atom (e.g., Si vs. Al), the distance between atoms in the solid, and the atomic arrangement (e.g., carbon vs. diamond).

In semiconductors and insulators, the valence band is filled, and no more electrons can be added, following Pauli's principle. Electrical conduction requires that electrons be able to gain energy in an electric field; this is not possible in these materials because that would imply that the electrons are promoted into the forbidden band gap. In metals, the electrons occupy states up to the *Fermi level*. Conduction occurs by promoting electrons into the *conduction band*, that starts at the Fermi level, separated by the valence band by an infinitesimal amount.

Electrical Resistivity of Metals

The resistivity then depends on collisions. Quantum mechanics tells us that electrons behave like waves. One of the effects of this is that electrons do not scatter from a perfect lattice. They scatter by defects, which can be:

-  atoms displaced by lattice vibrations
-  vacancies and interstitials
-  dislocations, grain boundaries
-  impurities

One can express the total resistivity ρ_{tot} by the Matthiessen rule, as a sum of resistivities due to thermal vibrations, impurities and dislocations. Fig. 19.8 illustrates how the resistivity increases with temperature, with deformation, and with alloying..

Semiconductivity

Intrinsic Semiconductor

Semiconductors can be *intrinsic* or *extrinsic*. Intrinsic means that electrical conductivity does not depend on impurities, thus intrinsic means pure. In extrinsic semiconductors the conductivity depends on the concentration of impurities. Conduction is by electrons and holes. In an electric field, electrons and holes move in opposite direction because they have opposite charges.

In an intrinsic semiconductor, a hole is produced by the promotion of each electron to the conduction band. Thus:

$$n = p$$

Extrinsic Semiconductor

Unlike intrinsic semiconductors, an extrinsic semiconductor may have different concentrations of holes and electrons. It is called *p-type* if $p > n$ and *n-type* if $n > p$. They are made by *doping*, the addition of a very small concentration of impurity atoms. Two common methods of doping are diffusion and ion implantation. Excess electron carriers are produced by substitutional impurities that have more valence electron per atom than the semiconductor matrix. For instance phosphorous, with 5 valence electrons, is an electron *donor* in Si since only 4 electrons are used to bond to the Si lattice when it substitutes for a Si atom. Thus, elements in columns V and VI of the periodic table are donors for semiconductors in the IV column, Si and Ge. The energy level of the donor state is close to the conduction band, so that the electron is promoted (ionized) easily at room temperature, leaving a hole (the ionized donor) behind. Since this hole is unlike a hole in the matrix, it does not move easily by capturing electrons from adjacent atoms. This means that the conduction occurs mainly by the donated electrons (thus *n-type*). Excess holes are produced by substitutional impurities that have fewer valence electrons per atom than the matrix. This is the case of elements of group II and III in column IV semiconductors, like B in Si. The bond with the neighbors is incomplete and so they can capture or accept electrons from adjacent silicon atoms. They are called *acceptors*. The energy level of the acceptor is close to the valence band, so that an electron may easily hop from the valence band to complete the bond leaving a hole behind. This means that conduction occurs mainly by the holes (thus *p-type*).

The Temperature Variation of Conductivity and Carrier Concentration

Temperature causes electrons to be promoted to the conduction band and from donor levels, or holes to acceptor levels. The dependence of conductivity on temperature is like other thermally activated processes:

$$\sigma = A \exp(-E_g/2kT)$$

where A is a constant (the mobility varies much more slowly with temperature). Plotting $\ln \sigma$ vs. $1/T$ produces a straight line of slope $E_g/2k$ from which the band gap energy can be determined. Extrinsic semiconductors have, in addition to this dependence, one due to the thermal promotion of electrons from donor levels or holes from acceptor levels. The dependence on temperature is also exponential but it eventually saturates at high temperatures where all the donors are emptied or all the acceptors are filled. This means that at low temperatures, extrinsic semiconductors have

larger conductivity than intrinsic semiconductors. At high temperatures, both the impurity levels and valence electrons are ionized, but since the impurities are very low in number and they are exhausted, eventually the behavior is dominated by the intrinsic type of conductivity.

	INTRINSIC SEMICONDUCTORS	EXTRINSIC SEMICONDUCTORS
1.	It is pure semi-conducting material and no impurity atoms are added to it.	It is prepared by doping a small quantity of impurity atoms to the pure semi-conducting material.
2.	Examples: crystalline forms of pure silicon and germanium.	Examples: silicon "Si" and germanium "Ge" crystals with impurity atoms of As, Sb, P etc. or In, B, Al etc.
3.	The number of free electrons in the conduction band and the no. of holes in valence band is exactly equal and very small indeed.	The number of free electrons and holes is never equal. There is excess of electrons in n-type semi-conductors and excess of holes in p-type semi-conductors.
4.	Its electrical conductivity is low. Its electrical conductivity is a function of temperature alone.	Its electrical conductivity is high. Its electrical conductivity depends upon the temperature as well as on the quantity of impurity atoms doped the structure.

Intrinsic semiconductor

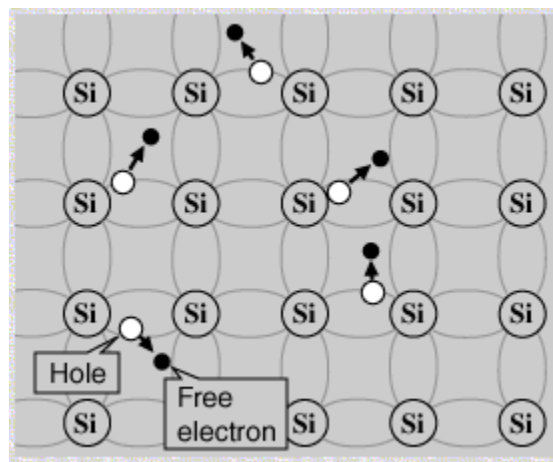

Extrinsic semiconductor

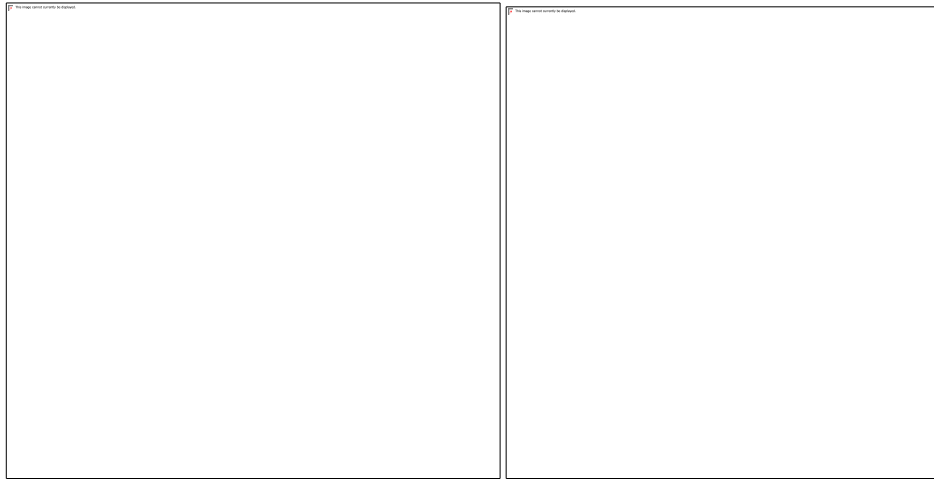

Semiconductor Devices

A **semiconductor diode** is made by the intimate junction of a *p*-type and an *n*-type semiconductor (an *n-p junction*). Unlike a metal, the intensity of the electrical current that passes through the material depends on the polarity of the applied voltage. If the positive side of a battery is connected to the *p*-side, a situation called *forward bias*, a large amount of current can flow since holes and electrons are pushed into the junction region, where they recombine (annihilate). If the polarity of the voltage is flipped, the diode operates under *reverse bias*. Holes and electrons are removed from the region of the junction, which therefore becomes depleted of carriers and behaves like an insulator. For this reason, the current is very small under reverse bias. The asymmetric current-voltage characteristics of diodes is used to convert alternating current into direct current. This is called rectification.

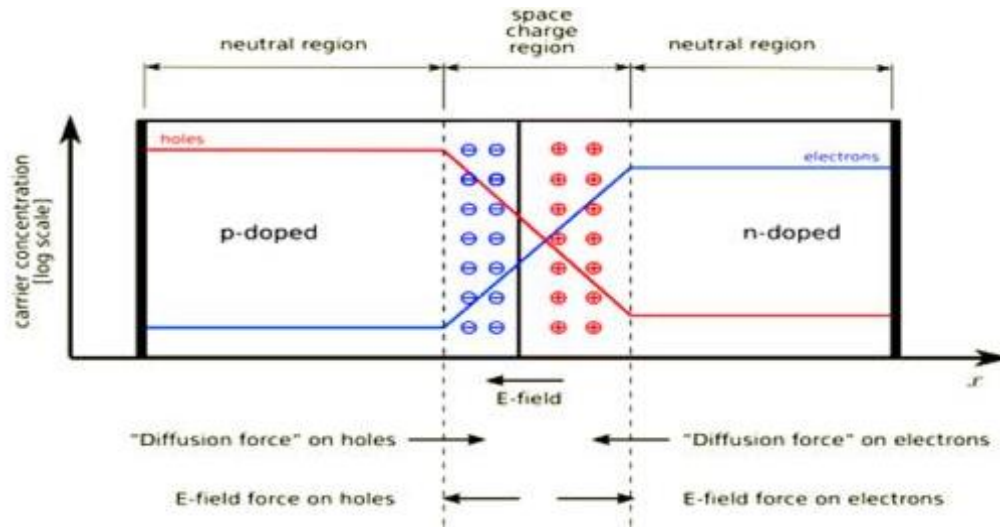

A **p-n-p junction transistor** contains two diodes back-to-back. The central region is very thin and is called the *base*. A small voltage applied to the base has a large effect on the current passing through the transistor, and this can be used to amplify electrical signals (Fig. 19.22). Another common device is the MOSFET transistor where a *gate* serves the function of the base in a junction transistor. Control of the current through the transistor is by means of the electric field induced by the gate, which is isolated electrically by an oxide layer.

Conduction in Ionic Materials

In ionic materials, the band gap is too large for thermal electron promotion. Cation vacancies allow ionic motion in the direction of an applied electric field, this is referred to as *ionic conduction*. High temperatures produce more vacancies and higher ionic conductivity. At low temperatures, electrical conduction in insulators is usually along the surface, due to the deposition of moisture that contains impurity ions.

Superconductivity:

Superconductivity is the ability of certain materials to conduct electrical current with no resistance and extremely low losses. This ability to carry large amounts of current can be applied to electric power devices such as motors and generators, and to electricity transmission in power lines. For example, superconductors can carry as much as 100 times the amount of electricity of ordinary copper or aluminum wires of the same size. Scientists had been intrigued with the concept of superconductivity since its discovery in the early 1900s, but the extreme low temperatures the phenomenon required was a barrier to practical and low-cost applications. This

all changed in 1986, when a new class of ceramic superconductors was discovered that "superconducted" at higher temperatures. The science of high-temperature superconductivity (HTS) was born, and along with it came the prospect for an elegant technology that promises to "supercharge" the way energy is generated, delivered, and used.

Meissner Effect & Superconductor Types

The Meissner effect is an expulsion of a magnetic field from a superconductor during its transition to the superconducting state. The German physicists Walther Meissner and Robert Ochsenfeld discovered the phenomenon in 1933 by measuring the magnetic field distribution outside superconducting tin and lead samples.

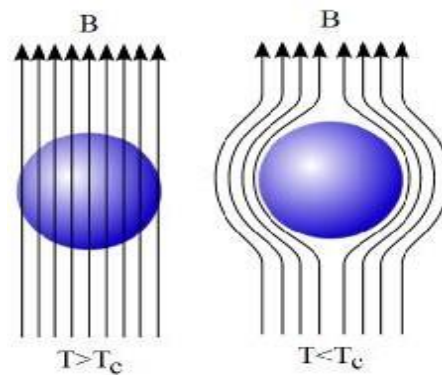

The interior of a bulk superconductor cannot be penetrated by a weak magnetic field, a phenomenon known as the Meissner effect. When the applied magnetic field becomes too large, superconductivity breaks down. Superconductors can be divided into two types according to how this breakdown occurs. In **type-I** superconductors, superconductivity is abruptly destroyed via a first order phase transition when the strength of the applied field rises above a critical value H_c . **Type-II** superconductor is characterized by the formation of magnetic vortices in an applied magnetic field. This occurs above a certain critical field strength H_{c1} . The vortex density increases with increasing field strength. At a higher critical field H_{c2} , superconductivity is completely destroyed.

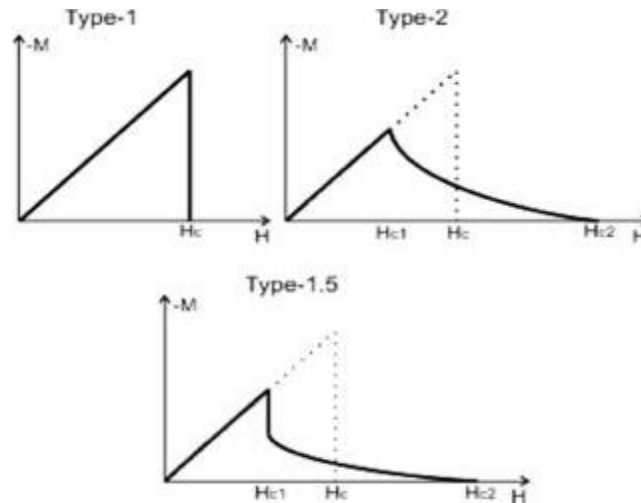

Ceramics (Applications and Processing)

Ceramics encompass such a vast array of materials that a concise definition is almost impossible. However, one workable definition is: Ceramics can be defined as inorganic, nonmetallic materials. They are typically crystalline in nature and are compounds formed between metallic and nonmetallic elements such as aluminum and oxygen (alumina- Al_2O_3), calcium and oxygen (calcia - CaO), and silicon and nitrogen (silicon nitride- Si_3N_4).

Ceramics is a refractory, inorganic, and nonmetallic material. Ceramics can be divided into two classes: traditional and advanced. Traditional ceramics include clay products, silicate glass and cement; while advanced ceramics consist of carbides (SiC), pure oxides (Al_2O_3), nitrides (Si_3N_4), non-silicate glasses and many others. Ceramics offer many advantages compared to other materials. They are harder and stiffer than steel; more heat and corrosion resistant than metals or polymers; less dense than most metals and their alloys; and their raw materials are both plentiful and inexpensive. Ceramic materials display a wide range of properties which facilitate their use in many different product areas.

In general, most ceramics are:

- ▣ hard,
- ▣ wear-resistant,
- ▣ brittle,
- ▣ refractory,
- ▣ thermal insulators,
- ▣ electrical insulators,



nonmagnetic,



oxidation resistant,

- ☐ prone to thermal shock, and
- ☐ Chemically stable.

Of course there are many exceptions to these generalizations. For example, borosilicate glasses (glasses that contain silica and boron as major ingredients) and certain glass ceramics (glasses that contain a crystalline phase) and NZP ceramics are very resistant to thermal shock and are used in applications such as ovenware, stove tops and kiln furniture respectively. Also, some ceramics are excellent electrical conductors and an entire commercial market is based on the fact that certain ceramics (ferrites) are magnetic.

Types and applications of ceramics:

Ceramics offer a high temperature range. However, ceramics are not very strong. To compensate for their lack of strength ceramics are usually combined with some other material to form a ceramic composite.

1) Glasses and glass ceramics- The glasses are a familiar group of ceramics; containers, windows, lenses and fiberglass represent typical applications. The properties of standard vitrified products are insufficient for architectural applications and structural building components, insulation or other specialized applications. Yet there is an effective way to improve these properties without major alterations to the process itself - the introduction of a controlled crystallization process through a subsequent heat treatment, i.e. by forming a glass-ceramic.

Production of Glass-Ceramics

Glass-ceramic articles may be produced by three routes:

- The heat treatment of solid glass (the traditional route)
- The controlled cooling of a molten glass, known as the peturgic method
- The sintering and crystallisation of glass powders.

In the latter case, the powders are densified at relatively low temperatures by exploiting a viscous flow sintering mechanism. After densification, the material is subjected to a crystallisation heat-treatment to obtain the required glass-ceramic microstructure. Alternatively, both densification and crystallisation may take place during a single sintering step. Along with the economic advantage of using relatively low processing temperatures, the powder technology route is

suitable for the production of a range of advanced materials, including glass-ceramics with specified porosities and glass-ceramic matrix composites.

Using the petrugic method, the slow cooling from the molten state causes nucleation and growth of certain crystalline phases. Therefore, the final microstructure, and hence the properties, depends mainly on the composition and the cooling rate.

Glass-Ceramics Based on Coal Ash

The very high iron oxide content of coal ash, table 1, indicates the potential for developing magnetic phases using appropriate processing - this was the aim of our work. We calcined the as-received ash at 800°C for two hours to remove any volatile Material compounds, including sulfur and carbon. The powder and petrugic methods were explored, and gave us products with different phases and microstructures. For the sintering experiments, we mixed calcined ash powder with various amounts (10-50wt%) of borosilicate (Pyrex) glass. The powder mixtures were uniaxial cold pressed to a cylindrical shape and sintered in air at temperatures in the range of 1,000-1,500°C for periods of up to 15 hours. Using the petrugic method, coal ash was mixed with sodalime glass powder. The mixture was melted at 1,500°C and cooled to room temperature at rates of between 1-10°C per minute.

Glass-Ceramic Composites

Work to date has largely concentrated on composites with a matrix of the slag-based Silceram glass-ceramic (a glass-ceramic for floor and wall tiles and wear components). We have investigated both particulate- (SiC and TiC) and fibre-reinforcement (SiC). Properties measured include the fundamental mechanical properties but also more complex properties such as thermal shock resistance and erosion resistance. As mentioned previously, the thermal shock resistance of glass-ceramics is superior to the parent glasses, and the shock resistance is further improved by particulate reinforcement. For example, monolithic Silceram has a thermal shock critical temperature of 180°C, whereas a 20wt%SiC composite has a value of 270°C. Erosion resistance may also be improved by particulate reinforcement, e.g., for TiC reinforced Silceram - the larger the reinforcement particle size and the greater the volume fraction, the lower the erosion rate. Results indicate a way for transforming vitrified silicate residues into useful products with broad

application potential. The glass-ceramics obtained are candidate materials for applications in floors of industrial buildings and in construction, and for outside and inside facing walls. We are currently addressing issues associated with the effect of environmental influences on the chemical durability and toxic potential of the materials, which may be compromised by the presence of heavy metals incorporated in the glass or crystalline phases. Public acceptance of the use and exploitation of glass-ceramic-based materials in such applications will strongly depend on a satisfactory consideration of these issues.

2) Refractories -Refractories are materials needed for handling high temperature liquids, gases and solids, e.g., for industrial processing. Applications include solar furnaces, casting molds for molten materials, heat exchangers, and aerobraking heat shields. Industrial refractory needs can be satisfied by sintered calcia (CaO), silica (SiO_2), magnesia (MgO), alumina (Al_2O_3) and titania (TiO_2), with the desired porosity. Of course, these stable materials are commonly used on Earth for the same purposes, due to their great resistance to heat, oxidation (they are already fully oxidized), corrosion and abrasion. Minerals such as olivine [$(\text{MgFe})_2\text{SiO}_4$] and anorthite ($\text{CaAl}_2\text{Si}_2\text{O}_8$) are also useful for making refractory bricks and ceramics. Some refractories and their ceramics have low expansion due to heat and are attractive for space environments where a wide range of temperatures are experienced.

One particular application of refractories is in transportation for returning cargoes to low Earth orbit by aerobraking with the upper atmosphere, and perhaps slowing down some incoming asteroid payloads by aerobraking. Of course, this is the method used by spacecraft to return to Earth, including the reusable Space Shuttle. The Space Shuttle's tiles are made from silica (SiO_2) (with a thin borosilicate coating to provide a smooth, aerodynamic surface for a smooth landing). Aerobraking tiles are produced from amorphous silica fibers which are pressed and sintered, with the resulting tile having as much as 93% porosity (i.e., very lightweight) and low thermal expansion, low thermal conductivity, and good thermal shock properties. This process can be readily performed in space when we can produce silica of the required purity. Cheaper materials besides silica fibers can be used. Silica fibers are used on the Space Shuttle in order to keep its weight down, thereby increasing cargo weight capacity. For resources already in space, we don't have this economic need. A number of other materials can be used for heat shields, e.g., alumina (Al_2O_3) or anorthite ($\text{CaAl}_2\text{Si}_2\text{O}_8$).

3) Abrasives- Abrasive cements are used to wear, grind or cut away other material, which necessarily is softer. Therefore, the prime requisite for this group of materials is hardness or wear resistance; in addition, a high degree of toughness is essential to ensure that the abrasive particles do not easily fracture. Furthermore, high temperatures may be produced from abrasive frictional forces, so some refractoriness is also desirable. Diamonds, both natural and synthetic, are utilized as abrasives; however, they are relatively expensive. The more common ceramic abrasives include silicon carbide, tungsten carbide(WC), aluminium oxide and silica sand. Abrasives are used in several forms-bonded to grinding wheels, as coated abrasives and as loose grains. Coated abrasives are those in which an abrasive powder is coated on some type of paper or cloth material; sandpaper is probably the mostly familiar example. Wood, metals, ceramics and plastics are all frequently ground and polished using this form of abrasive. Grinding, lapping and polishing wheels often employ loose abrasive grains that are delivered in some type of oil or water based vehicle. Diamonds, corundum, silicon carbide and rouge are used in loose form over a variety of grain size ranges.

4) Cements: Several familiar ceramic materials are classified as inorganic cements: cements, plaster of paris, and lime, which as a group are produced in extremely large quantities. The characteristic feature of these materials is that when mixed with water, they form a paste that subsequently sets and hardens. This trait is especially useful in that solid and rigid structures having just about any shape may be expeditiously formed.

Portland Cement

Portland cement is a closely controlled chemical combination of calcium, silicon, aluminum, iron and small amounts of other compounds, to which gypsum is added in the final grinding process to regulate the setting time of the concrete. Some of the raw materials used to manufacture cement are limestone, shells, and chalk or marl, combined with shale, clay, slate or blast furnace slag, silica sand, and iron ore. Lime and silica make up approximately 85 percent of the mass. The term "Portland" in Portland cement originated in 1824 when an English mason obtained a patent for his product, which he named Portland Cement. This was because his cement blend produced concrete that resembled the color of the natural limestone quarried on the Isle of Portland in the English Channel. Different types of Portland cement are manufactured to meet different physical and chemical requirements for specific purposes.

Common Examples

Structural clay products Brick, sewer pipe, roofing tile, clay floor and wall tile (i.e., quarry tile), flue linings

Whitewares Dinnerware, floor and wall tile, sanitaryware, electrical porcelain, decorative ceramics

Refractories Brick and monolithic products are used in iron and steel, non-ferrous metals, glass, cements, ceramics, energy conversion, petroleum, and chemicals industries

Glasses Flat glass (windows), container glass (bottles), pressed and blown glass (dinnerware), glass fibers (home insulation), and advanced/specialty glass (optical fibers)

Abrasives Natural (garnet, diamond, etc.) and synthetic (silicon carbide, diamond, fused alumina, etc.) abrasives are used for grinding, cutting, polishing, lapping, or pressure blasting of materials

Cements Used to produce concrete roads, bridges, buildings, dams, and the like

Fabrication and processing of ceramics

Ceramic Synthesis

Our expertise and capabilities in synthesizing ceramics are based on chemical solution techniques. Chemical solution or sol-gel approaches have been developed to fabricate powders, films, and porous bodies. Materials of interest range from silica to complex, multicomponent electronic ceramics. The complexity inherent in fabricating materials with structured nanoporosity or complex chemistries requires a fundamental understanding of these chemical solution approaches. Fabrication of unique precursors for complex oxides is being done with novel metal alkoxide chemistry to produce powders and thin-film materials with carefully controlled properties. Our ability to synthesize materials with complex structures, chemistries, or both, is at the heart of numerous research and development efforts at Sandia.

Ceramic Processing

Sandia's fabrication of ceramic components and devices is based on a strong ceramic-processing capability. We recently have demonstrated the ability to characterize and model the powder-compaction process in detail, and to address and control density gradients in powder compacts

that cause shape distortion and differential shrinkage. Proprietary 3D, finite-element code packing and compaction models, and process-control tools are now available to improve the production of ceramic components. Sandia has capabilities in the areas of hydrostatic and triaxial compaction testing to characterize materials properties, and x-ray radiography, ultrasound, and computed tomography for density characterization. In addition, expertise in slurry processing has enabled the development of direct-fabrication processes. Furthermore, we are developing phenomenological sintering models to enhance both ceramic component design and manufacturing capability.

COMPOSITES

Particle-reinforced composites

These are the cheapest and most widely used. They fall in two categories depending on the size of the particles:

- large-particle composites, which act by restraining the movement of the matrix, if well bonded.
- dispersion-strengthened composites, containing 10-100 nm particles, similar to what was discussed under precipitation hardening. The matrix bears the major portion of the applied load and the small particles hinder dislocation motion, limiting plastic deformation.

Large-Particle Composites

Properties are a combination of those of the components. The *rule of mixtures* predicts that an upper limit of the elastic modulus of the composite is given in terms of the elastic moduli of the matrix (E_m) and the particulate (E_p) phases by:

$$E_c = E_m V_m + E_p V_p$$

where V_m and V_p are the volume fraction of the two phases. A lower bound is given by:

$$E_c = E_m E_p / (E_p V_m + E_m V_p)$$

Concrete

The most common large-particle composite is concrete, made of a cement matrix that bonds particles of different size (gravel and sand.) Cement was already known to the Egyptians and the

Greek. Romans made cement by mixing lime (CaO) with volcanic ash. In its general form, cement is a fine mixture of lime, alumina, silica, and water. Portland cement is a fine powder of chalk, clay and lime-bearing minerals fired to 1500°C (calcinated). It forms a paste when dissolved in water. It sets into a solid in minutes and hardens slowly (takes 4 months for full strength). Properties depend on how well it is mixed, and the amount of water: too little - incomplete bonding, too much – excessive porosity.

The advantage of cement is that it can be poured in place, it hardens at room temperature and even under water, and it is very cheap. The disadvantages are that it is weak and brittle, and that water in the pores can produce cracks when it freezes in cold weather. Concrete is cement strengthened by adding particulates. The use of different size (stone and sand) allows better packing factor than when using particles of similar size.

Concrete is improved by making the pores smaller (using finer powder, adding polymeric lubricants, and applying pressure during hardening). *Reinforced concrete* is obtained by adding steel rods, wires, mesh. Steel has the advantage of a similar thermal expansion coefficient, so there is reduced danger of cracking due to thermal stresses. *Pre-stressed concrete* is obtained by applying tensile stress to the steel rods while the cement is setting and hardening. When the tensile stress is removed, the concrete is left under compressive stress, enabling it to sustain tensile loads without fracturing. Pre-stressed concrete shapes are usually prefabricated. A common use is in railroad or highway bridges. *Cermets* are composites of ceramic particles (strong, brittle) in a metal matrix (soft, ductile) that enhances toughness. For instance, tungsten carbide or titanium carbide ceramics in Co or Ni. They are used for cutting tools for hardened steels.

Reinforced rubber is obtained by strengthening with 20-50 nm carbon-black particles. Used in auto tires.

Dispersion-Strengthened Composites

Use of very hard, small particles to strengthen metals and metal alloys. The effect is like precipitation hardening but not so strong. Particles like oxides do not react so the strengthening action is retained at high temperatures.

Fiber-reinforced composites

In many applications, like in aircraft parts, there is a need for high strength per unit weight (specific strength). This can be achieved by composites consisting of a low density (and soft) matrix reinforced with stiff fibers.

The strength depends on the fiber length and its orientation with respect to the stress direction.

The efficiency of load transfer between matrix and fiber depends on the interfacial bond.

Structural Composites

Largest and most diverse use of composites due to ease of fabrication, low cost and good properties.

Glass-fiber reinforced composites (GFRC) are strong, corrosion resistant and lightweight, but not very stiff and cannot be used at high temperatures. Applications include auto and boat bodies, aircraft components.

Carbon-fiber reinforced composites (CFRC) use carbon fibers, which have the highest specific module (module divided by weight). CFRC are strong, inert, allow high temperature use. Applications include fishing rods, golf clubs, aircraft components. Kevlar, and aremid-fiber composite can be used as textile fibers. Applications include bullet-proof vests, tires, brake and clutch linings.

Wood

This is one of the oldest and the most widely used structural material. It is a composite of strong and flexible cellulose fibers (linear polymer) surrounded and held together by a matrix of lignin and other polymers. The properties are anisotropic and vary widely among types of wood. Wood is ten times stronger in the axial direction than in the radial or tangential directions.

Smart materials

Smart materials are designed materials that have one or more properties that can be significantly changed in a controlled fashion by external stimuli, such as stress, temperature, moisture, pH, electric or magnetic fields.

Group of new and state-of-the-art materials now being developed, and expected to have significant influence on present-day technologies, especially in the fields of medicine, manufacturing and defense. Smart/Intelligent material system consists some type of sensor (detects an input) and an actuator (performs responsive and adaptive function).

Actuators may be called upon to change shape, position, natural frequency, mechanical characteristics in response to changes in temperature, electric/magnetic fields, moisture, pH, etc.

Four types of materials used as actuators: Shape memory alloys, Piezo-electric ceramics,

Magnetostrictive materials, Electro-/Magneto-rheological fluids. Materials / Devices used as sensors: Optical fibers, Piezo-electric materials, Micro-electro-mechanical systems (MEMS), etc. Typical applications: By incorporating sensors, actuators and chip processors into system, researchers are able to stimulate biological human-like behavior; Fibers for bridges, buildings, and wood utility poles; They also help in fast moving and accurate robot parts, high speed helicopter rotor blades; Actuators that control chatter in precision machine tools; Small microelectronic circuits in machines ranging from computers to photolithography prints; Health monitoring detecting the success or failure of a product.

Nano-materials

Nanostructured materials are those materials whose structural elements—clusters, crystallites or molecules have dimensions in the range of 1-100 nm. These small groups of atoms, in general, go by different names such as nanoparticles, nanocrystals, quantum dots and quantum boxes. Substantial work is being carried out in the domain of nanostructured materials and nanotubes during the past decade since they were found to have potential for high technology engineering applications. One finds a remarkable variations in fundamental electrical, optical and magnetic properties that occur as one progresses from an ‘infinitely extended’ solid to a particle of material consisting of a countable number of atoms. The various types of nanostructured materials which has been considered for applications in opto-electronic devices and quantum-optic devices are nano-sized powders of silicon, silicon-nitride (SiN), silicon-carbide (SiC) and their thin films. Some of these are also used as advanced ceramics with controlled micro structures because their strength and toughness increase when the grain size diminishes. Carbon-based nanomaterials and nanostructures including fullerenes and nanotube plays an increasingly pervasive role in nanoscale science and technology. Today, nanotechnology is being heralded as the next enabling technology that will redesign the future of several technologies, products and markets.

FRACTURE



Fundamentals of Fracture

Fracture is a form of failure where the material separates in pieces due to stress, at temperatures below the melting point. The fracture is termed ductile or brittle depending on whether the elongation is large or small. Steps in fracture (response to stress):

- Crack formation
- Crack propagation

Ductile Fracture

Stages of ductile fracture

-  Initial necking
-  Small cavity formation (micro voids)
-  Void growth (ellipsoid) by coalescence into a crack

Fast crack propagation around neck. Shear strain at 45°

Final shear fracture (cup and cone)

The interior surface is fibrous, irregular, which signify plastic deformation.

Brittle Fracture

There is no appreciable deformation, and crack propagation is very fast. In most brittle materials, crack propagation (by bond breaking) is along specific crystallographic planes (*cleavage* planes). This type of fracture is transgranular (through grains) producing grainy texture (or faceted texture) when cleavage direction changes from grain to grain. In some materials, fracture is intergranular.

Fracture occurs due to *stress concentration* at flaws, like surface scratches, voids,

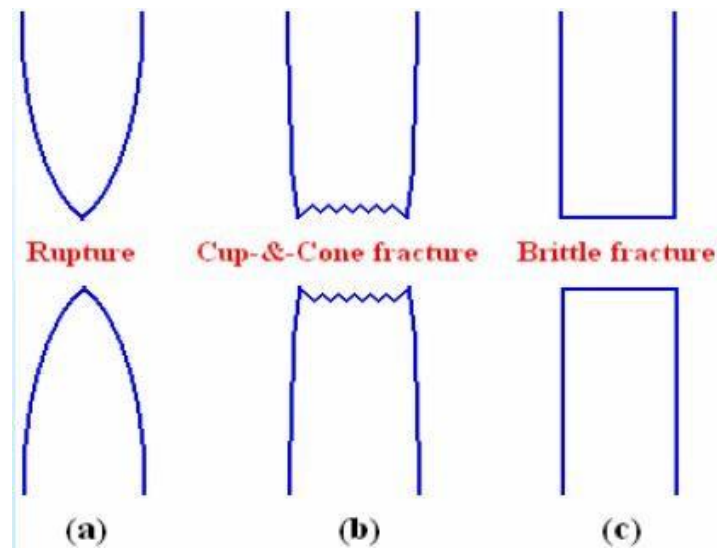

Parameter	Ductile fracture	Brittle fracture
Strain energy required	Higher	Lower
Stress, during cracking	Increasing	Constant
Crack propagation	Slow	Fast
Warning sign	Plastic deformation	None
Deformation	Extensive	Little
Necking	Yes	No
Fractured surface	Rough and dull	Smooth and bright
Type of materials	Most metals (not too cold)	Ceramics, Glasses, Ice

Impact Fracture:

Impact fractures can best be described as a flute or strip of material that was cleanly sheared from a projectile point. The most common type of impact fracture starts at the tip of a point and runs down one blade edge possibly reaching the shoulder of a point. Some points were reworked into a useable point after having been damaged by an impact fracture. Normalized tests, like the Charpy and Izod tests measure the *impact energy* required to fracture a notched specimen with a hammer mounted on a pendulum. The energy is measured by the change in potential energy (height) of the pendulum. This energy is called *notch toughness*.

FATIGUE

Fatigue is the catastrophic failure due to dynamic (fluctuating) stresses. It can happen in bridges, airplanes, machine components, etc. The characteristics are:

- long period of cyclic strain
- the most usual (90%) of metallic failures (happens also in ceramics and polymers)
- is brittle-like even in ductile metals, with little plastic deformation
- it occurs in stages involving the initiation and propagation of cracks.

Cyclic Stresses

These are characterized by *maximum*, *minimum* and *mean stress*, the *stress amplitude*, and the *stress ratio*.

Crack Initiation and Propagation

Stages of fatigue failure:

- I. crack initiation at high stress points (stress raisers)
- II. propagation (incremental in each cycle)
- III. final failure by fracture

Stage I - propagation

- slow
- along crystallographic planes of high shear stress
- flat and featureless fatigue surface

Stage II - propagation

Crack propagates by repetitive plastic blunting and sharpening of the crack tip.

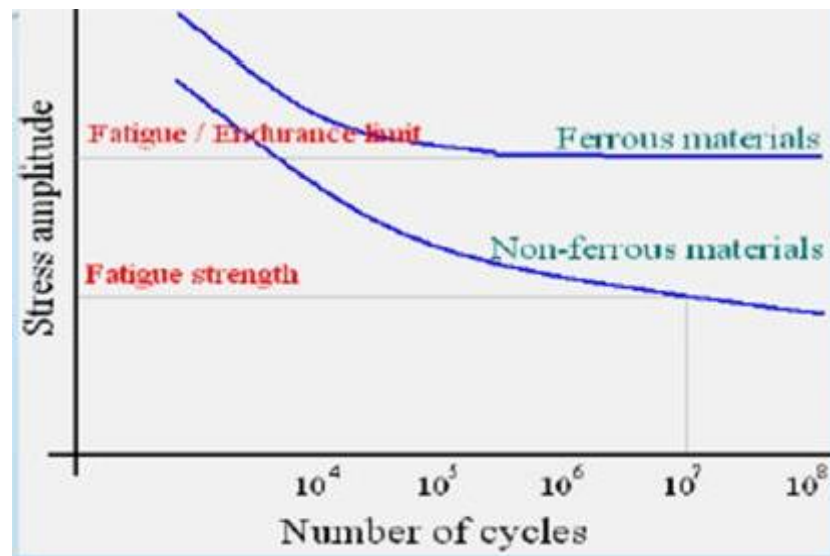

Corrosion and Degradation of Materials

Corrosion of Metals

The *corrosion resistance* of metals and **alloys** is a basic property related to the easiness with which these materials react with a given environment. Corrosion is a natural process that seeks to reduce the binding energy in metals. The end result of corrosion involves a **metal atom being oxidized**, whereby it loses one or more electrons and leaves the bulk metal. The lost electrons are conducted through the bulk metal to another site where they are reduced. In corrosion parlance, the site where metal atoms lose electrons is called the anode, and the site where electrons are transferred to the reducing species is called the cathode.



Pure metals are used in many applications. Copper, for example, is used to make the wire which goes inside electrical cables. Copper was chosen because it can be drawn into long thin wires very easily (it is ductile) and because it is a good conductor of electricity. Pure aluminum can also be used in wiring. It is also used as a cladding material for aluminum alloy substrates.

Currently there are 86 known metals. Before the 19th century only 24 of these metals had been discovered and, of these 24 metals, 12 were discovered in the 18th century. Therefore, from the discovery of the first metals, gold and copper, until the end of the 17th century, some 7700 years, only 12 metals were known. Four of these metals, arsenic, antimony, zinc and bismuth, were discovered in the thirteenth and fourteenth centuries, while platinum was discovered in the 16th century. The other seven metals, known as the Metals of Antiquity, were the metals upon which civilization was based. These seven metals are Gold, Copper, Silver, Lead, Tin, Iron, Mercury.

Corrosion of Ceramics:

It is often said that one of the biggest advantages which ceramics have over other materials is their corrosion resistance, that is, their chemical inertness in corrosive environments. Is this always true?

Corrosion is generally understood as property degradation due to environmental attack. As it will be shown in this section, there are a number of environments in which ceramics can degrade at a rapid rate. There exists a tremendous need for reliable and corrosion resistant structural ceramic or partly ceramic materials which can be used in aggressive environments such as:

-  high energy battery systems (such as sodium-sulphur): beta-alumina is being investigated
-  gas turbines: silicon nitride and/or carbide are being investigated
-  heat exchangers: SiC, composites are being investigated

Ceramics are indeed much more environmentally stable, as compared to any other group of engineering materials, e.g. metals or plastics. Still, the potential for ceramics as corrosion resistant engineering structural materials are far from being fully realized, because of:

- mechanical nonreliability of structural ceramic components
- difficult design with brittle materials
- a shortage of information and standardization of ceramics
- human reluctance to use non-ductile materials

Issues of particular importance when considering corrosion of ceramics:

- The resistance of many ceramics to wetting by a corrosive liquid is a valuable property. Little corrosion is expected if a liquid does not wet a ceramic. This is why, for example, boron nitride (BN) and graphite are useful in handling melts and including the extremely corrosive melts of silicate glasses. BN and graphite are not wetted by these liquids.
- The solubility of the reaction product in the corrosive environment (liquid) is critical to the extent of corrosion. Reaction barriers can form and prevent corrosion. Some examples are silica on silicon carbide or nitride, and alumina on Al. On the other hand, continuous dissolution of the reaction product can occur and sustain corrosion even for small chemical driving force, for instance Al_2O_3 in molten KOH.
- Even if a major component of the ceramic is resistant to a given corrosive environment, a minor phase (especially a grain boundary phase, in particular under stress) could be corroded (leached), leading to the general failure of the component. Some examples include:
 - Alumina in water, where preferential attack of the grain boundary glassy (silicate) phases occurs.

The preferential attack of free Si in reaction bonded SiC, by alkalis or nonmetals.

The oxide grain boundary phases in nonoxides (B_2O_3 in BN, silicates in SiN and SiC) are sensitive to water.

Severe corrosion takes place if the ceramic is in contact with a substance which can combine with it and form low-melting liquids (i.e. with eutectic point below ambient temperature).

The example of above situation is the system composed of metallurgical slag in contact with refractories. If the reaction is thermodynamically possible, the corrosion will proceed at a dramatic rate if the refractory is wetted by the slag.